



**USING AND MAINTENANCE MANUAL FOR INJECTION-EXTRACTION MACHINES**



**Cutlass**



**Sabre**



**Sabre Junior**

**READ CAREFULLY BEFORE USING THE MACHINE**

## Generalities

The injection-extraction machines mod. Sabre JNR, Cutlass and Sabre, designed to clean carpet and hard floor, are formed by the body, the hoses and the wand.

The body is composed by two high-density polyethylene tanks, kept together through lateral elastic hooks. The upper tank (recovery tank) is foreseen to contain the dirty water sucked from the carpet or floor. The lower tank (solution tank) is foreseen to contain the water and the chemical detergent. The lower tank also contains the motor group, the pump and the control panel. In the model Sabre the control panel is located on the upper tank.



### Safety instructions (read carefully)

Every electrical device must be used for its particular function only, respecting the manufacturer's instructions. Failure to adhere to the instructions could result in serious person injury, electric shock, fire or explosion.

The nowadays machines are normally produced according to the accident prevention regulations and are often homologated by qualified institutes for the safety, but nobody and nothing can save irresponsible users from danger.

Please, read carefully the following points and be sure to understand everything before using the machines. The following information signals potentially dangerous conditions to the operator or equipment.



#### **WARNING: Fire or Explosion Hazard.**

- Do not spray water near electrical outlets.
- Do not use the machine to spray or to suck dust, corrosive liquids (acids or bases) and explosive or inflammable liquids.
- Do not use the machine in an explosive atmosphere. This machine is not equipped with an explosion proof motor. The electric motor will spark when powered on which could cause a flash fire or explosion if machine is used in an area where flammable vapors/liquids or combustible dusts are present.
- Never use flammable liquids or operate machine in or near flammable liquids, vapors or combustible dusts.



#### **WARNING: Electrical Hazard.**

- Before putting the machine's plug in the current socket, check that the voltage available is the same indicated on the label of the machines.
- Be sure that the electrical system is well earthed and that it has a safety differential switch.
- Verify that the cable plug is complying with the outlet.
- Do not modify plug.

- Do not use adapters or multiple sockets, without knowing the electrical input of each user.
- If any electrical extension is used, check that it corresponds to the absorbed power of the machine and that the connection of the plug with the socket is complying and sealed.
- Take care of the electrical cable. It must be integral and protected from water, tears and chemical agents. Do not repair the cable in case of tears, but replace it with a new one. The cable must be replaced by the manufacturer or its service agent or a similarly qualified person in order to avoid a hazard.
- Do not pull the cable to drag the machine or to pull the plug out.
- Pull the plug out only when the machine is switched off.
- Do not handle the plug with wet hands.
- Unplug cable before servicing machine.



**FOR SAFETY:**

- Do not let the machine being used by children and people unable to understand the danger connected with the use of electrical power.
- Do not bring the end of the suction hose or one of the accessories near your face or others', particularly near ears and eyes: the sucked air could seriously damage them.
- If the machine is used as a wet vacuum cleaner, you must check the level of water in the recovery tank, in order to prevent water from being sucked by the vacuum motor.
- If the chemical you are using produces foam, or if you are cleaning carpet previously treated with shampoo, you must put some antifoaming liquid into the recovery tank. In the long run, the foam sucked by the motor can damage it.
- In case of abnormal working (very noisy motor, not running pump, extreme temperature rise, or other suspicious signals) switch off the machine and pull the plug out.
- If foam or liquid escapes from the machine, switch machine off immediately.
- After using, store the machine, well cleaned, in a cool and dry place.

The manufacturer cannot be held responsible for any damage/injury caused to persons or property, because of the incorrect use of the machine due to procedures being used which are not specified in this instruction manual.

**Attention:** all the electrical repairs must be performed by qualified personal only!



**PROTECT THE ENVIRONMENT**

Please dispose of packaging materials and old machine components in a safe environmentally way according to your local waster disposal regulations.



**Always remember to recycle.**

## Preparation for work

For the setting of your machine, make the following operations:

1. Raise the upper tank after having released it by acting on the lateral hooks (for the models Sabre JNR and Cutlass only).

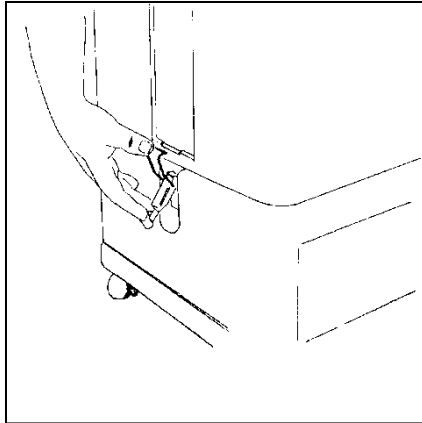

2. Fill the solution tank with cold or warm water, through the filling hole, adding a 5% of non-foaming detergent (1/2 liter in 10 liters). Higher concentrations may be used in case of particularly dirty surfaces.

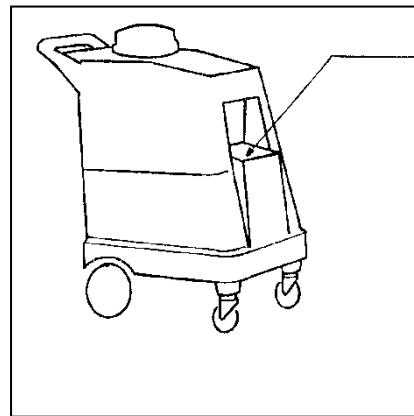
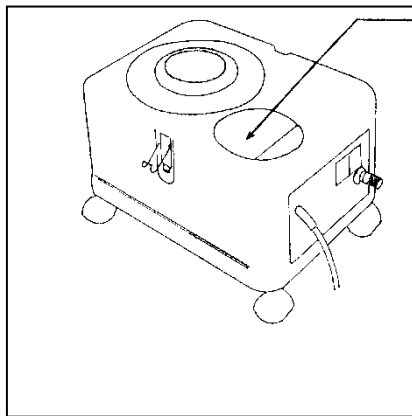

**Attention:** wool carpet must be washed with cold water only!

3. Reconnect the upper tank to the lower tank with the lateral hooks (for the models Sabre JNR and Cutlass only).
4. Connect the machine to the wand or to the accessory with the solution and with the vacuum hoses. The quick-disconnect couplings at the end of the solution hose (the thin one) must be inserted in the correspondent couplings: one is on the body of the machine and the other one is on the water valve that you find on the wand or on the accessory handle.

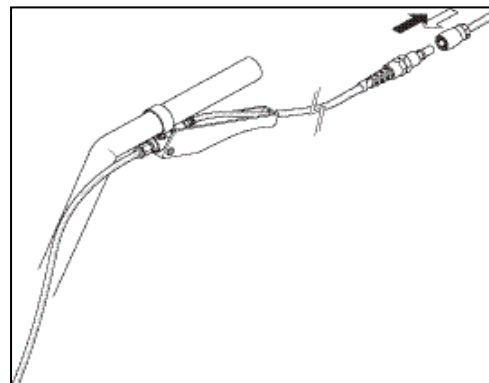
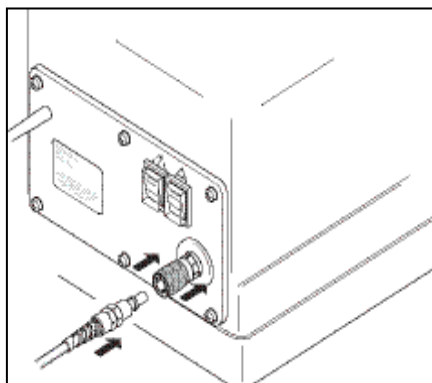

5. In the same way, you must connect the vacuum hose to the machine and to the accessory handle.

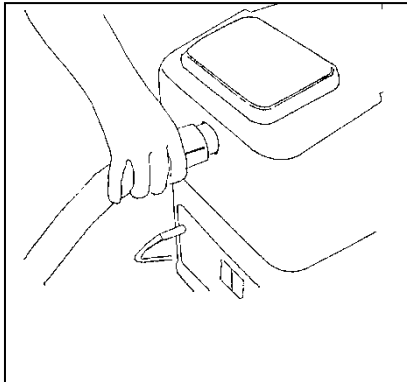

6. Put the plug of the cable in the socket (see safety regulations).

7. Switch on the water pump and vacuum motor through the corresponding switches.

At this point the machine is ready to operate.

**Attention:** Do not use the machine as a vacuum cleaner! (The machine cannot be used as a vacuum cleaner, unless you are using the optional accessory NS270DUST, which is provided with a filter inside in order to collect dust).

Do not let the pump run dry!

### **Working method**

For a routine maintenance cleaning of the carpet or floor, it is suitable to proceed by spraying and washing simultaneously. Push the lever on the wand handle to spray the solution.

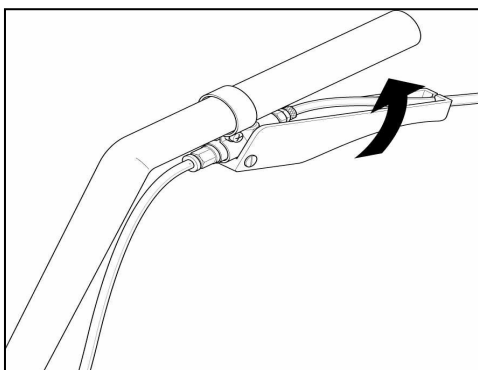

You can apply pure detergent on persistent spots, by using aerosol bombs which you can find on the market with solvents suitable to any kind of spot. Use quality and suitable detergents only, in order to avoid damages to the surfaces. Always test the chemical on a small spot where a possible damage cannot be seen.

Concerning the washing method, considering a rectangular surface, we suggest you should do as follows: after removing as much furniture as you can, divide ideally the surface in several stripes and proceed from left to right. Cover backwards each stripe for a part corresponding to a little more than a half of the length.

Invert then the direction and clean the remaining part in the same way. Work more or less slowly according to the dirtiness degree of the surface.

For a deep cleaning of carpet, some users suggest to spray the solution and leave it on the surfaces for some minutes before sucking it. In this way the detergent has more time to act on the dirt. Each operator will use his own method, also considering the type of carpet to clean.

## **Maintenance**

The models Sabre JNR, Cutlass and Sabre are professional machines. The warranty on these machines is of 1 year and covers the faults due to manufacturing defects. The faults due to improper use are not covered by warranty. For further details regarding warranty, contact the distributor supplying the machine.

Observe the following advice to obtain a perfect working and a long life of your machine:

1. After every use, before storing the machine, remove all the water from the solution and the recovery tank. Put some liters of clean water into the solution tank and use the pump only, pressing the lever of the solution valve. This operation is useful to clean the internal parts of the pump, of the couplings and nozzles, removing the detergent residues.
2. After every use, store the machine in a cool and dry place with the cover open, to avoid that humidity inside the recovery tank can condensate on the internal parts of the vacuum motor, therefore damaging it. The damage provoked by humidity that condenses on the motor (or the foam sucked by the motor) is not covered by warranty.
3. Periodically clean the water filter, extracting it from the machine and rinsing it under current water.
4. Periodically check and clean the filter of the vacuum motor, which is located between the 2 tanks for the models Sabre JNR and Cutlass, while for Sabre is located under the transparent circular cover of the upper tank.
5. Eliminate the lime that in time deposits inside the hydraulic circuit of the machine, by putting some anti-lime solution in the solution tank and leave it for some hours. Then empty the tank and rinse. It is enough to perform this operation every 6-8 months.
6. Periodically check the consume of the carbon brushes of the vacuum motor. This check should be done after 500 working hours.
7. For Cutlass and Sabre, it is also necessary to check the carbon brushes of the water pump, after 500 working hours.
8. Worn-out carbon brushes may result in damages to the vacuum motor or to the pump, which are not covered by warranty. The check of carbon brushes should be done by technical personnel.



ABN: 51 121 002 104

59 Radford Road, Reservoir VICTORIA 3073

Phone: (03) 9460 5655 Fax: (03) 9460 5666

Email: [sales@cleanstar.com.au](mailto:sales@cleanstar.com.au) Web: [www.cleanstar.com.au](http://www.cleanstar.com.au)

## **CONDITIONS OF WARRANTY**

**This document outlines the terms and conditions of warranty for your Cleanstar product. This is an important document that should be kept with your proof of purchase documents in a safe place for future reference should you require service for your product.**

Thank you for purchasing your new Cleanstar product. We are confident this product will give you trouble-free use and excellent service, provided the operator uses and maintains the product in accordance with the Instruction Manual. Please read the Instruction Manual carefully before using the product for correct operation and maintenance procedures, and store it in a safe place for future reference.

1. This is a parts and labour warranty against faulty or defective parts, materials or workmanship in manufacturing, when the product is used and operated in accordance with the Instruction Manual.
2. This product carries a 12 month (1 year) warranty period that commences from the original date of purchase by the first user/purchaser, and is not transferable.
3. This warranty only applies to products purchased and used in Australia.
4. The pump is designed only to have water through it. Where it is found that chemical has gone through the pump, this will void your warranty. Chemical will damage the pump, seals, and other associated parts which will not be covered under warranty.
5. At all times during the warranty period, Cleanstar shall, at its sole discretion, determine whether repair, replacement or refund will apply if the product has a valid warranty claim applicable to it.
6. The repair or replacement of the product under this warranty does not extend the original period of warranty.
7. Please note that this warranty will be voided in the following cases (which are not exhaustive) and the warranty does not apply to the cost of replacing any parts of the product resulting from:
  - Accidental damage;
  - Normal wear and tear;
  - Neglect, misuse or physical abuse by the operator, including failure to properly maintain or service;
  - Any alterations, modifications or tampering with the product without the prior written consent of Cleanstar;
  - Incomplete or improper installation;
  - Incorrect, improper or inappropriate operation;
  - Insect or vermin infestation;
  - Power surges, electrical storm damage or incorrect power supply/voltage;
  - Excessive use or use for which this product has not been designed;
  - Vacuuming up toner, powders, glass, hazardous, flammable or corrosive materials, plaster dust, concrete dust and other similar building or construction materials;
  - Failure to comply with the operating instructions contained in the Manual supplied with the product;
  - If the product is rented;
  - If the product is used outside of Australia;
  - If the product was serviced or repaired by anyone other than Cleanstar, or one of Cleanstar's Authorised Service Agents (ASA). Cleanstar is unable to accept any responsibility under this warranty for any repair work not carried out by an ASA or from the use of non-genuine parts.
8. This warranty does not cover service calls, travelling time or consumable parts such as belts, dust bags, filters, hose or hose parts, rods and wands, floor tools and accessories, motor brushes and other like consumable items, unless defective in manufacture. In order to prolong the life of accessories and consumables, regular care and maintenance is recommended.
9. Please retain your original proof of purchase which will be required before you can make a claim under this warranty. If proof of purchase can not be provided at the time of a warranty claim or service, any work carried out on the cleaner is chargeable.
10. Any transportation and delivery costs involved in the repair of defective parts shall be borne by the claimant. In all instances, unless the product is transported by Cleanstar or a Cleanstar authorised representative, the product is transported at the owner's cost and risk while in transit to and from Cleanstar or its ASA.

Our goods come with guarantees that cannot be excluded under the Australian Consumer Law. You are entitled to a replacement or refund for a major failure and for compensation for any other reasonably foreseeable loss or damage. You are also entitled to have the goods repaired or replaced if the goods fail to be of acceptable quality and the failure does not amount to a major failure. The benefits conferred by this warranty are in addition to other rights and remedies under law in respect of the product to which this warranty relates.

### **TO INQUIRE ABOUT MAKING A CLAIM UNDER THIS WARRANTY, PLEASE FOLLOW THESE STEPS:**

- a) carefully check the Instruction Manual and the terms of this warranty;
- b) have the name and model number of the appliance available;
- c) have the proof of purchase available (ie. invoice, receipt, etc) showing where the appliance was purchased from and date of purchase;
- d) call Cleanstar on (03) 9460 5655 to speak to one of our customer service staff.