



T581

BATTERY FLOOR SCRUBBER

OPERATOR'S MANUAL (EN)



Model Part No.:
LPTB03306 - SCRUBBER [T581 60CM,CD,PD,ANZ]



ANZ



To view, print or download
the parts manual, visit:
www.tennantco.com/manuals

www.tennantco.com

PLDC04600
Rev. 01 (07-2022)

ENGLISH
**(Translation of original
instructions)**

TABLE OF CONTENTS

TECHNICAL SPECIFICATIONS	4
MACHINE DIMENSIONS	6
SAFETY SYMBOLS	7
GENERAL INFORMATION	8
Purpose of this manual	8
Identifying the machine	8
Documentation provided with the machine	8
TECHNICAL INFORMATION	9
General description	9
Parts of the machine	9
Danger zones	10
Accessories	10
SAFETY INFORMATION	11
Safety precautions	11
MOVEMENT INSTALLATION	14
Lifting and transporting the packaged machine	14
Delivery checks	14
Unpacking	14
Batteries (Battery version)	14
Batteries: preparation	15
Batteries: installation and connection	15
Batteries: removal	16
Choosing a battery charger	16
Preparing the battery charger	16
Squeegee installation and adjustment	17
Squeegee adjustment	17
Brush installation	18
Lifting and transporting the machine	19
PRACTICAL GUIDE FOR THE OPERATOR	20
Preparing the machine for work	20
Controls	21
Working	24
Some useful tips to get the most from your scrubber drier	24
Emptying the collection tank:	24
Emptying the water/detergent tank	25
Filling the water/detergent tank	25
Filling the Chem-Dose tank (accessory)	26
Finishing work	26
Moving the machine when not in operation	26
PERIODS OF INACTIVITY	27
MAINTENANCE INSTRUCTIONS	28
Maintenance - General rules	28
Cleaning the suction motor air filter	28
Cleaning the water/detergent tank filter	29
Cleaning the dirty water tank float	29
Fuses: replacing	30
Battery maintenance and charging	32
Replacing the squeegee blades	34
Pushing and pulling the machine:	35
Periodic checks	36
TROUBLESHOOTING	37
DISPLAY ALARMS	38
TECHNICAL MENU	40
RECOMMENDED SPARE PARTS	41

TECHNICAL SPECIFICATIONS

		55	60	70
Cleaning width	mm	530	614	678
	inch	21	24	28
Squeegee width	mm	710	942	942
	inch	28	37	37
Cleaning capacity per hour	m ² /h	3180	3684	4068
	ft ² /h	34229	39654	43787
Number of brushes	n°	1	2	2
Brush diameter	mm	530	310	345
	inch	21	13	14
Maximum brush pressure	g/cm ²	10,3	62,6	43,7
	kPa	0,98	6,8	4,3
Brush rotation speed	g/1° RPM	150	220	220
Brush motor power	W	400	2 x 400	2 x 400
	HP	0,53	2 x 0,53	2 x 0,53
Drive motor power	W	300		
	HP	0,4		
Maximum speed	Km/h	6		
	mph	3,7		
Suction motor power	W	480 (2 stadi)	480 (3 stadi)	480 (3 stadi)
	HP	0,64	0,64	0,64
Solution tank	L	75		
	gal	20		
Dirty water tank	L	80		
	gal	21		
Rear wheel diameter	mm	225		
	inch	8,8		
Maximum slope	%	8	16	16

Gross weight	Kg	418	430	431
	lbs	921,5	947,9	950
Transported weight	Kg	293	293	293
	lbs	645,9	645,9	645,9
Number of batteries	n°	2	4	4
Battery voltage	V	12	6	6
Individual battery capacity	Ah (5h)	105	180	180
Power system voltage	V	24		
Machine dimensions	mm	X=1310 Z=673 Y=1030	X=1310 Z=675 Y=1030	X=1310 Z=760 Y=1030
	inch	X=51,5 Z=26,4 Y=40,5	X=51,5 Z=26,5 Y=40,5	X=51,5 Z=29,9 Y=40,5
Battery compartment dimensions (length, width, height)	mm	390x478x260		
	inch	15,3x18,8x10,2		
Packed size (length, width, height)	mm	1445x795x1140		
	inch	56,8x31,2x44,8		
Sound pressure	LpA (dB)	57 dB 56 dB (Eco)	58 dB 57 dB (Eco)	58 dB 57 dB (Eco)
Measurement uncertainty	K (dB)	3,2	3,2	3,2
Vibration level (hand)	HAV m/sec ²	1,5	1,3	1,3
Measurement uncertainty, k	m/sec ²	0,8	0,6	0,6
Vibration level (body)	HBV m/sec ²	0,6	0,6	0,6
Measurement uncertainty, k	m/sec ²	0,3	0,3	0,3
Maximum water and detergent temperature	°C	da 4 a 55		



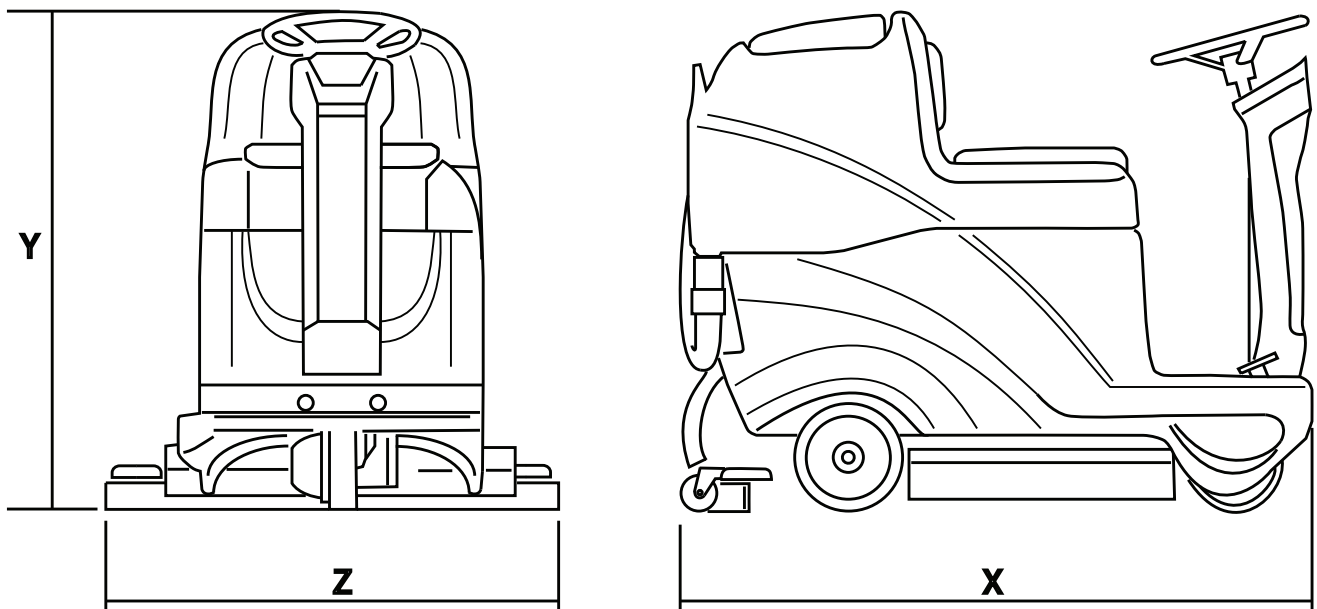

Data subject to variation without warning.

MACHINE DIMENSIONS



X-Y-Z: See "TECHNICAL SPECIFICATIONS" table

SAFETY SYMBOLS

	MAXIMUM SLOPE
	OPERATOR'S MANUAL, OPERATING INSTRUCTIONS
	READ THE OPERATOR'S MANUAL
	DIRECT CURRENT SYMBOL
	INSULATION CLASS, THIS CLASSIFICATION ONLY APPLIES TO MACHINES POWERED BY BATTERIES.

GENERAL INFORMATION

Purpose of this manual

This manual has been written by the Manufacturer and is an integral part of the **machine**¹. It defines the purpose for which the machine has been designed and constructed and contains all the information required by **operators**².

In addition to this manual, which contains information for operators, other publications are available providing specific information for **maintenance personnel**³.

The terms "right" and "left", "clockwise" and "anti-clockwise" refer to the forward movement of the machine.

Constant compliance with the instructions provided in this manual guarantees the safety of the operator and the machine, ensures low running costs and high quality results and extends the working life of the machine. Failure to follow these instructions may lead to injury to the operator or damage to the machine, floor and environment.

Consult the table of contents at the beginning of the manual to find the section you need rapidly. Parts of the text requiring special attention are printed in bold and preceded by the symbols illustrated and described here.

! DANGER!

Indicates the need for attention in order to avoid a series of consequences which could cause death or serious injury to personnel.

! WARNING!

Indicates the need for attention in order to avoid a series of consequences which could cause injury to personnel or damage to the machine or work environment or financial loss.

! IMPORTANT!

Important information.

In line with the company's policy of constant product development and updating, the Manufacturer reserves the right to make modifications without prior notice.

Although your machine may differ appreciably from the illustrations in this document, the correctness and validity of the instructions contained in this manual are guaranteed.

Identifying the machine

The nameplate provides the following information:

- ▶ Model
- ▶ Battery voltage
- ▶ Total rated power
- ▶ Rated current draw
- ▶ Serial number
- ▶ Year of manufacture
- ▶ IP Index of Protection
- ▶ Dry weight
- ▶ Maximum negotiable gradient
- ▶ Name of manufacturer

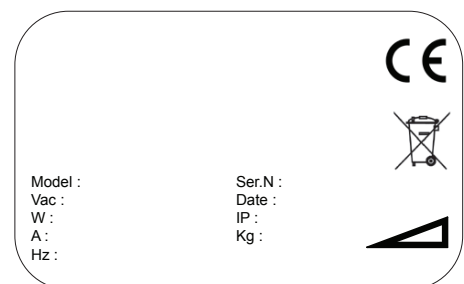

Documentation provided with the machine

- ▶ Operator's manual
- ▶ Certificate of warranty
- ▶ Wall Chart

¹ The definition "machine" replaces the trade name covered by this manual.

² Persons responsible for using the machine without performing any operations requiring precise technical skills.

³ Persons with experience, technical training and a knowledge of legislation and standards, able to perform all the necessary operations and to recognise and avoid possible risks in handling, installation, use and maintenance of this machine.

TECHNICAL INFORMATION

General description

This machine is a scrubber drier for sweeping, washing and drying flat, horizontal, smooth or moderately rough, even and obstacle free floors in civil and industrial premises.

The scrubber drier spreads a solution of water and detergent in the correct concentration on the floor and then scrubs it to remove the dirt. By carefully choosing the detergent and brushes (or abrasive disks) from the wide range of accessories available, the machine can be adapted to a wide range of combinations of types of floor and dirt.

A suction system incorporated in the machine dries the floor after washing by means of the low pressure generated in the dirty water tank by the suction motor. The squeegee connected to the tank collects the dirty water.

Parts of the machine

The machine comprises the main parts described below (fig. 1).

- ▶ The water/detergent tank (fig. 1, ref. 1) contains and carries the mixture of clean water and cleaning product.
- ▶ The dirty water tank (fig. 1, ref. 2) collects the dirty water picked up from the floor after washing;
- ▶ Control panel (fig. 1, ref. 3).
- ▶ Head assembly (fig. 1, ref. 4), the main element comprises the brushes/rollers which distribute the detergent solution onto the floor and remove the dirt.
- ▶ Squeegee assembly (fig. 1, ref. 5): wipes and dries the floor by collecting the water.



Danger zones

- ▶ Control panel: risk of injury from short circuits.
- ▶ Tank assembly: when using certain detergents, danger of irritation for eyes, skin, mucous membranes and respiratory tract and of asphyxia. Danger represented by the dirt collected from the environment (germs and chemical substances). Danger of crushing between the two tanks when the dirty water tank is replaced on top of the detergent tank.
- ▶ Washing head assembly: danger due to brush rotation.
- ▶ Front/rear wheels: risk of crushing between the wheels and chassis.
- ▶ Danger of short circuit between the battery poles and presence of hydrogen during charging.

Accessories

- ▶ Soft, hard and abrasive brushes.
- ▶ Chem-Dose tank.
- ▶ NORD ELETTRONICA NE284 - S.P.E.CHBHD1-XR-P battery charger for single-brush version
- ▶ S.P.E. CBHD3/CHBHD1-XR-P battery charger for double-brush version

SAFETY INFORMATION

Safety precautions

! DANGER!

Read this Operator's Manual carefully before start-up and use and before performing any maintenance or other work on the machine.

! WARNING!

Rigorously follow all the instructions in this Operator's Manual (in particular those marked "Danger!" and "Warning!". Also respect the safety labels applied to the machine (see the "[Safety symbols](#)" section.

The Manufacturer declines all liability for injury to persons or damage to property resulting from failure to follow instructions.

The machine must be used exclusively by persons trained in its use and/or who have demonstrated their ability and have been expressly authorised to use it.

The machine must not be used by minors.

The machine must not be used for purposes other than those for which it was expressly designed. Scrupulously respect all safety standards and conditions applicable to the type of building in which the machine is to be operated (e.g.: pharmaceutical companies, hospitals, chemicals, etc.).

This machine is intended for use in commercial applications, such as hotels, schools, hospitals, factories, shops and offices, or for hire.

The machine must only be used indoors.

Do not use the machine without a protection structure (FOPS) in areas where the operator could be struck by falling objects.

Warning, the machine must be kept in closed environments at all times.

Do not use the machine in inadequate lighting, explosive atmospheres, on public roads, to clean dirt that is hazardous to health (dust, gas, etc.) or in unsuitable environments.

The machine is designed to operate in temperatures between +4°C and +40°C. It can be stored in temperatures between +0°C and +50°C when not in use.

The machine is designed to operate at relative humidity levels between 0% and 95%.

Never use the machine to clean up flammable or explosive liquids (e.g. petrol, fuel oil, etc.), acids or solvents (e.g. paint solvents, acetone etc.) even if diluted. Never clean up burning or incandescent objects.

Never use the machine on slopes or ramps more than specified in "[Technical specifications](#)"; never drive sideways across even gentle slopes. Always manoeuvre with care and avoid reversing. When transiting steeper ramps or slopes, take the utmost care to prevent tipping and/or uncontrolled acceleration.

Never park the machine on a slope.

Never leave the machine unattended with the motor or engine on. Before leaving it, turn the motor or engine off and make sure it cannot move accidentally.

Always pay attention to other people, especially children, in the place where you are working.

Children must be supervised to make sure they do not play with the machine.

The machine is not intended for use by persons (including children) with reduced physical, sensory or mental capabilities, or lack of experience and knowledge, unless they are supervised by a person responsible for their safety and have received instruction in the use of the machine.

Never use the machine to transport people or goods or to tow things.

Do not tow the machine.

Never rest objects of any weight on the machine for any reason.

Never obstruct the ventilation and heat dispersion openings.

Never remove, modify or circumvent safety devices.

Numerous unpleasant experiences have shown that a wide range of personal objects may cause serious accidents. Before beginning work, remove jewellery, watches, ties, etc..

The operator must always use personal protection devices: protective apron or overalls, non-slip waterproof shoes, rubber gloves, protective goggles and ear protectors and mask to protect the

respiratory tract.

Keep hands away from moving parts.

Make sure the power sockets used for the battery charger are connected to a suitable earth system and protected by thermal magnetic and earth leakage breakers.

Make sure the electrical characteristics of the machine (voltage, frequency, power) given on the nameplate correspond to those of the mains electricity supply.

It is indispensable to respect the battery manufacturer's instructions and applicable legislation. The batteries should always be kept clean and dry to avoid surface leakage current. Protect the batteries from impurities such as metal dust.

Never rest tools on the batteries as they could cause short circuits leading to explosions.

When using battery acid, always follow scrupulously the safety instructions given in the "[Batteries: preparation](#)" section.

Battery charger (OPTIONAL): check the power cable regularly for damage. If the power cable is damaged, do not use the charger; to replace the cable, contact a specialist service centre.

If particularly strong magnetic fields are present, assess their possible effect on the control electronics.

To recharge the batteries, always use the battery charger supplied with the machine (when provided).

Never wash the machine with water jets.

In the case of malfunction and/or faulty operation, turn the machine off immediately (disconnecting it from the mains power supply or batteries) and do not tamper with it. Contact a service centre authorised by the Manufacturer.

All maintenance operations must be performed in an adequately illuminated area and only after disconnecting the machine from the power supply.

All work on the electrical system and all maintenance and repair operations other than those explicitly described in this manual must be performed by specialist and experienced personnel only.

! DANGER!

When lifting the dirty water tank (after having first been emptied) to access the compartment, the safety bracket must be inserted in position, to stop the tank from accidentally closing again (Fig. 29).

29

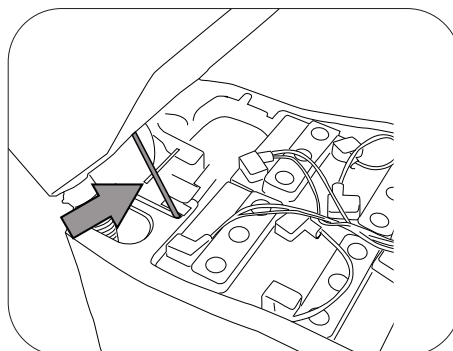

Only use original accessories and spare parts supplied by the Manufacturer to guarantee safe and problem-free operation of the machine. Never use parts removed from other machines or from other kits.

The machine is designed and constructed to provide ten years' service from the date of manufacture shown on the nameplate. After this period, whether the machine has been used or not, it should be disposed of according to current legislation in the country in which it is used.

It should be disconnected from the power supply, emptied of all liquids and cleaned prior to disposal. The machine is classified as WEEE type special waste and is covered by the requirements of applicable environmental protection regulations (2002/96/EC WEEE).

The machine must be disposed of separately from ordinary waste in compliance with current legislation and standards.

If you decide to stop using the machine, remove the batteries and dispose of them through an authorised recycling centre.

Also make sure that all parts of the machine that could represent a hazard, particularly to children, are made safe.

Alternatively, return the machine to the Manufacturer for a complete overhaul.



MOVEMENT INSTALLATION

Lifting and transporting the packaged machine

! WARNING!

During all lifting operations, make sure the packaged machine is firmly secured to avoid it tipping up or being accidentally dropped.

Always load/unload lorries in adequately illuminated areas.

The machine is packaged on a wooden pallet by the Manufacturer. It must be loaded on to the transporting vehicle using suitable equipment (see EC Directive 89/392 and subsequent amendments and/or additions). At destination, it must be unloaded using similar means.

A fork lift truck must always be used to lift the packaged body of the machine. Handle with care to avoid knocking or overturning the machine.

Delivery checks

When the carrier delivers the machine, make sure the packaging and machine are both whole and undamaged. If the machine is damaged, make sure the carrier is aware of the damage and before accepting the goods, reserve the right (in writing) to request compensation for the damage.

Unpacking

! WARNING!

When unpacking the machine, the operator must be provided with the necessary personal protection devices (gloves, goggles, etc.) to limit the risk of injury.

Proceed as follows to unpack the machine.

- ▶ Cut and remove the plastic straps using scissors or nippers.
- ▶ Remove the cardboard packaging.
- ▶ Remove the bags from the battery compartment and check their contents:
this Operator's Manual, the maintenance manual, declaration of conformity, certificate of warranty;
battery bridges with terminals;
connector for battery charger.

Depending on the model, remove the metal brackets or cut the plastic straps fixing the machine chassis to the pallet.

Using a sloping ramp, push the machine backwards off the pallet; see the paragraph "[Pushing and pulling the machine](#)" for details on engaging/disengaging the electric brake on the drive wheel.

Unpack the brushes from their packaging.

Clean the outside of the machine, taking care to respect safety regulations.

Once the machine is clear of the packaging, proceed to install the batteries (see the "[Batteries: installation and connection](#)" section).

The packaging may be kept and reused to protect the machine if it is moved to another site or to a repair workshop.

Otherwise it must be disposed of in compliance with current legislation.

Batteries (Battery version)

Two different types of battery may be installed on these machines:

- ▶ Leak-proof tubular batteries: these require regular checks on electrolyte level. When necessary, top up with distilled water until the plates are covered. Do not over-fill (5 mm max. above the plates).
- ▶ Sealed batteries: this type of battery requires no maintenance.

Battery technical characteristics must correspond to those listed in the [Technical specifications](#) section. The use of higher capacity batteries could seriously jeopardise manoeuvrability and lead to the drive motor overheating. Batteries with a lower capacity and weight will require charging more frequently.

Batteries must be kept charged, dry and clean and the connections must be kept tight.

! IMPORTANT!

Follow the instructions below to configure the machine's software for the type of batteries installed:

see the "[Technical menu](#) section".

Batteries: preparation

! DANGER!

During battery installation and any type of battery maintenance, the operator must be provided with the necessary personal protection devices (gloves, goggles overalls, etc.) to limit the risk of injury. Keep clear of naked flames, avoid short circuiting the battery poles, avoid sparks and do not smoke.

Batteries are normally supplied filled with acid and ready for use.

If the batteries are dry, proceed as follows before installing them in the machine.

Remove the caps and fill all elements with sulphuric acid solution specific for batteries until the plates are entirely covered (this requires at least a couple of passes for each element).

Leave the batteries stand for 4-5 hours to allow air bubbles to come to the surface and the plates to absorb the electrolyte.

Make sure the level of electrolyte is still above the plates and if necessary top up with sulphuric acid solution.

Close the caps.

Install the batteries in the machine (following the procedure described below).

Charge the batteries before starting up the machine for the first time. Follow the instructions in the "[Battery maintenance and charging](#)" section.

Batteries: installation and connection

! DANGER!

Check that all switches on the control panel are in the "0" (off) position.

Make sure you connect the terminals marked with a "+" to the positive poles of the battery.

Do not check the battery charge by sparking.

Meticulously follow the instructions given below as short circuiting the batteries could cause them to explode.

Place the batteries in the battery compartment, orienting them as shown in the drawings (figs. 2 and 3). On machines fitted with two batteries, place the polystyrene spacers supplied between the compartment and the batteries, see the drawing (fig. 3)

Referring to the cable layout shown in the above diagram, connect the battery cables and bridge terminals to the battery poles. Arrange the cables as shown in the diagram, tighten the terminals on the poles and coat with Vaseline.

Lower the tank into the working position.

When using the machine, follow the instructions below.

! WARNING!

Never allow the batteries to become excessively flat as this could damage them irreparably.

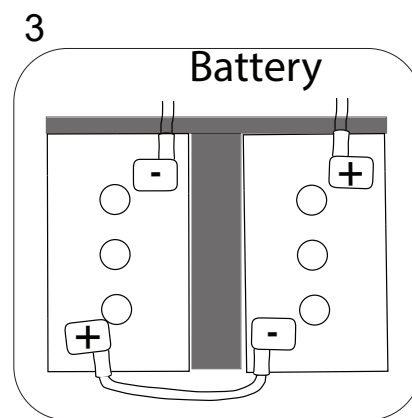
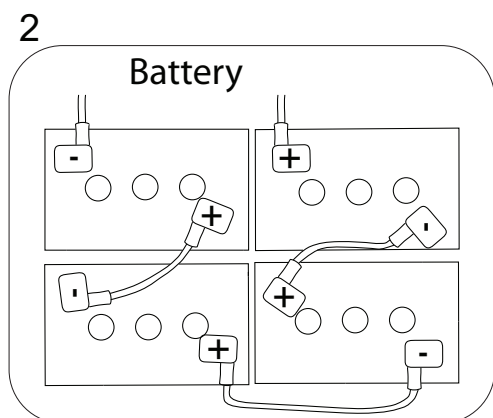

Batteries: removal

! DANGER!

When removing the batteries, the operator must be equipped with suitable personal protection devices (gloves, goggles, overalls, safety shoes, etc.) to reduce the risk of injury. Make sure the switches on the control panel are in the “0” position (off) and the machine is turned off. Keep away from naked flames, do not short circuit the battery poles, do not cause sparks and do not smoke. Proceed as follows.

- ▶ Disconnect the battery cables and bridge terminals from the battery poles.
- ▶ If necessary, remove the devices fixing the battery to the base of the machine.
- ▶ Lift the batteries from the compartment using suitable lifting equipment.

Choosing a battery charger

Make sure the battery charger is compatible with the batteries to be charged.

Tubular lead batteries: an automatic charger is recommended. Consult the battery charger manufacturer and manual to confirm the choice.

Gel batteries: use a charger specific for this type of battery.

! DANGER!

Use CE-marked battery chargers that comply with the relevant product standards (EN60335-2-29), featuring double or reinforced insulation between input and output, and a SELV output circuit.

Preparing the battery charger

If you wish to use a battery charger not provided with the machine, you must fit it with the connector supplied with the machine.

The connector supplied for the external battery charger is suitable for cables with a minimum cross-section of 16 mm².

Proceed as follows to fit the connector:

Remove about 13 mm of protective sheath from the red and black cables of the battery charger.

Insert the wires into the connector contacts and squeeze them forcefully with suitable pliers.

Respect the polarity (red wire + black wire –) when inserting the wires into the connector.

Squeegee installation and adjustment

Switch the machine on, lower the squeegee by pressing the suction motor button.

Place the squeegee in the slots provided on the support (fig. 4), then tighten the fastening knobs and insert the suction hose.

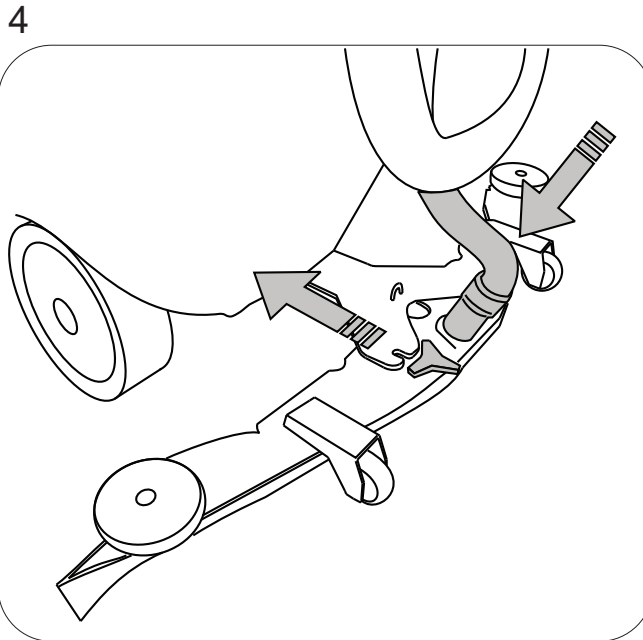

Squeegee adjustment

The squeegee blades scrape the film of water and detergent from the floor and prepare the way for perfect drying. With time, the constant rubbing makes the edge of the blade in contact with the floor rounded and cracked, reducing the drying efficiency and requiring it to be replaced. The state of wear should be checked frequently.

For perfect drying, the squeegee must be adjusted in such a way that the edge of the rear blade bends during operation by about 45° with respect to the floor at every point. The angle of the blades can be adjusted using the screw (fig. 5, ref. 1), while the height of the squeegee from the floor can be adjusted by changing the height of the two wheels (fig. 6).

5

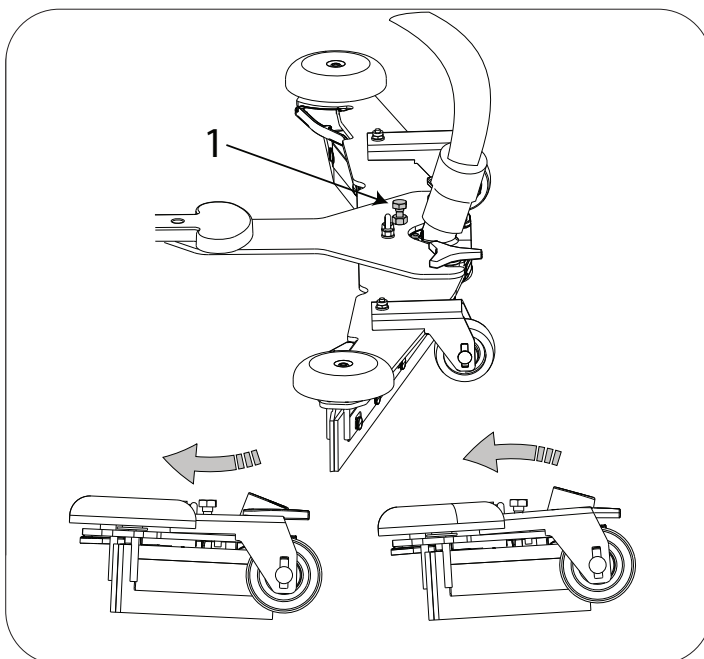

6

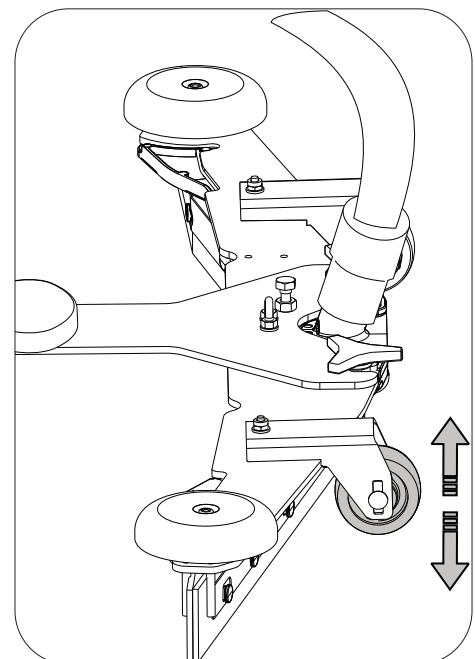

Brush installation

Single-brush machine:

position the brush underneath the head, in the centre (Fig. 7); switch the machine on. Pressing the ATTACH/RELEASE button once after starting the machine releases the brushes, pressing the button a second time activates automatic brush attachment; the button is only enabled when all the functions are deactivated (suction motor and brushes).

7

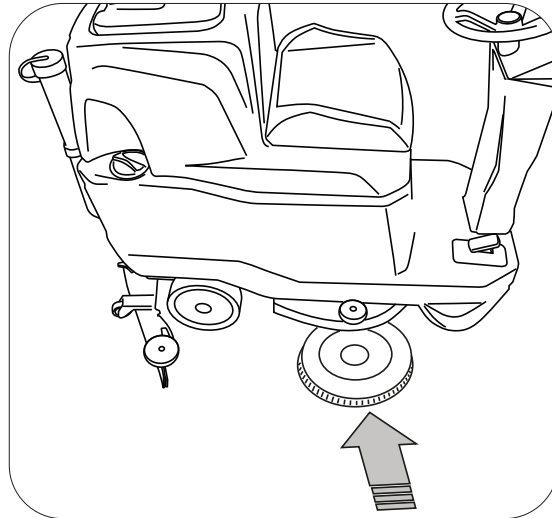

Double-brush machine:

position the brushes underneath the head on both sides (Fig. 8), the brushes should rest on the brush centering device in the centre of the head; switch the machine on.

Pressing the ATTACH/RELEASE button once after starting the machine releases the brushes, pressing the button a second time activates automatic brush attachment; the button is only enabled when all the functions are deactivated (suction motor and brushes).

8

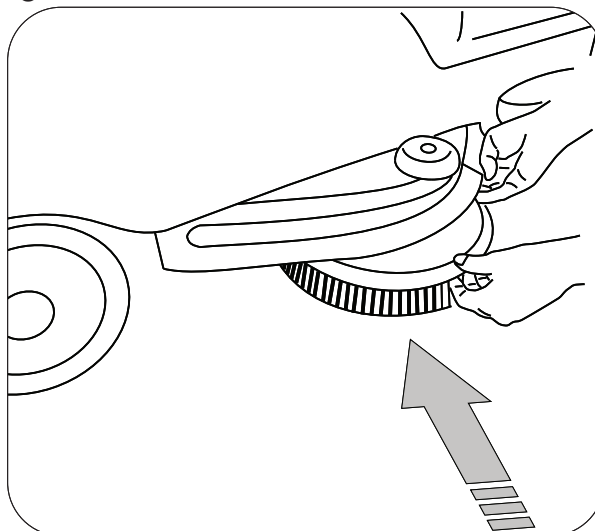

! IMPORTANT!

Follow the instructions given below to configure the machine's control software to use the display language you require.

See the "[Technical menu](#)" section.

Lifting and transporting the machine

! WARNING!

All phases of lifting and moving must be performed in an adequately illuminated environment with the adoption of the safety measures most appropriate to the situation.

The operator must always use personal protection devices.

Proceed as follows to load the machine onto a means of transport.

- ▶ Empty the tanks.
- ▶ Remove the batteries.
- ▶ Position the machine on a pallet and fix it in place with plastic straps or metal brackets.
- ▶ Lift the pallet (with the machine) using a fork lift truck and load it onto the means of transport.
- ▶ Anchor the machine to the means of transport with cables connected to the pallet and to the machine itself.

PRACTICAL GUIDE FOR THE OPERATOR

! WARNING!

Before starting work, wear overalls, ear protectors, non-slip and waterproof shoes, mask to protect the respiratory tract, gloves and all other personal protection devices necessitated by the work environment.

! WARNING!

Do not leave the machine unattended or parked with the key in the switch and the parking brake disengaged.

! IMPORTANT!

If you are using the machine for the first time, we recommend trying it out on a large obstacle-free surface first to acquire the necessary familiarity.

! WARNING!

To avoid damaging the surface of the floor you are cleaning, avoid rotating the brushes with the machine stationary.

! IMPORTANT!

The machine is fitted with a driver detection device. It is only possible to start the machine while seated correctly in the driving seat. The device halts the machine if you get up from the seat.

! WARNING!

Always dilute the detergent according to the manufacturer's instructions. Do not use sodium hypochlorite (bleach) or other oxidants, particularly in strong concentrations. Do not use solvents or hydrocarbons. The water and detergent temperature must not exceed the maximum indicated in the "[Technical specifications](#)". They must be free of sand and/or other impurities.

The machine has been designed for use with low-foam biodegradable detergents made specifically for scrubber driers.

For a complete and up-to-date list of the detergents and chemicals available, contact the Manufacturer:

Use products suitable for the floor and dirt to be removed only.

Follow the safety regulations on use of detergents given in the section "Safety regulations".

Preparing the machine for work

Proceed as follows before starting work.

- ▶ Check that the display shows the batteries to be fully charged. Recharge if necessary. See the "[Battery maintenance and charging](#)" section.
- ▶ Make sure that the dirty water tank is empty. Empty it if necessary, see "[Emptying the dirty water tank](#)".
- ▶ Make sure that the solution tank is full. Fill it if necessary, see "[Filling the water/detergent tank](#)". If the machine is not fitted with the "Chem-Dose" accessory, add detergent to the tank in the required percentage, using the measuring cap.
- ▶ Open the water valve (tap) before operating the machine (fig. 8A, ref. 1).

8A

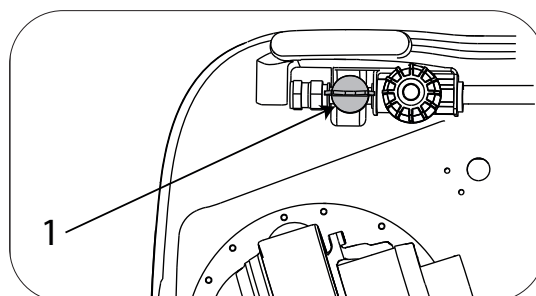

Controls

- ▶ **Emergency switch (fig. 9, ref. 1):** pushing the safety lever towards the tank, when necessary or in the event of imminent danger, stops all the machine's functions, opening the electrical circuit that supplies power to the machine.
- ▶ **Accelerator pedal (fig. 9, ref. 2):** press this pedal to control the speed of the machine. If the accelerator pedal is released for more than three seconds while the machine is switched on, the "AUTO POWER-OFF" function switches off all machine functions. To start again, simply press the accelerator pedal. To enable/disable and change the delay for "AUTO POWER-OFF" mode, go to the ["Technical menu"](#).
- ▶ **Battery charger socket (fig. 10):** if the machine is not fitted with a battery charger, to recharge the batteries, plug in the connector highlighted, see ["Preparing the battery charger"](#).
- ▶ **Main switch (fig. 11, ref. 1):** Switches power to all machine functions on/off.

9

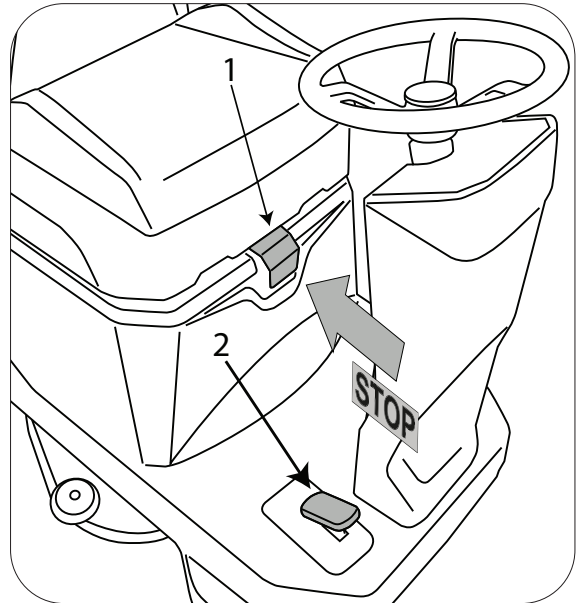

10

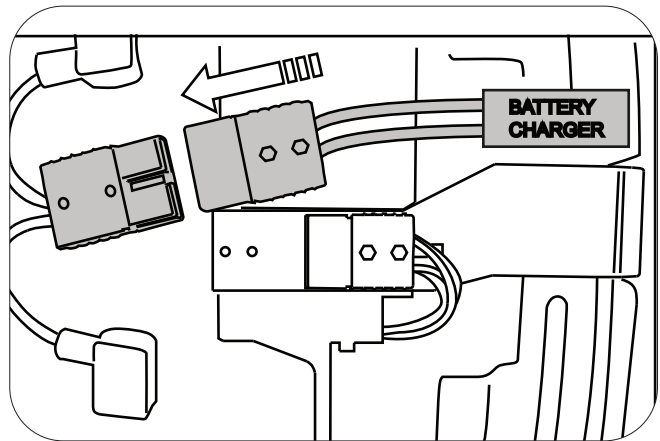

11

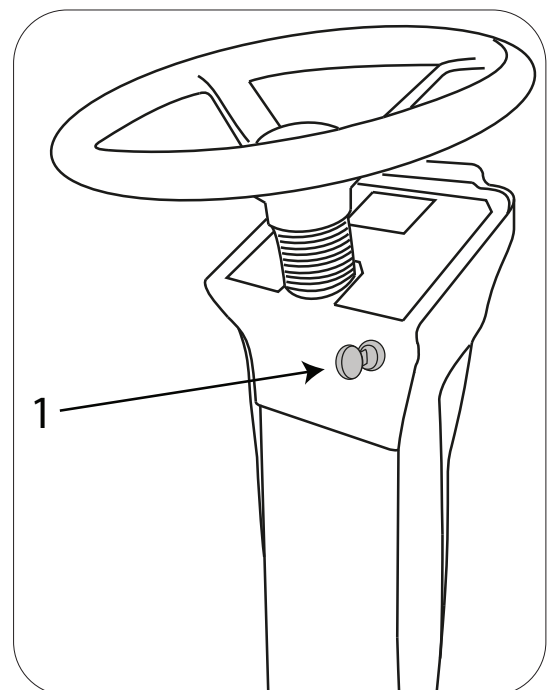

- ▶ **Suction button (fig. 12, ref. 1):** during operation with the AUTO, ECO or APC programs, starts/stops the suction motor; outside of these programs, starts the suction motor in manual mode, lowering the squeegee.
- ▶ **Water/detergent button (fig. 12, ref. 2):** during operation with the AUTO, ECO and APC programs, starts and stops (holding the button for two seconds) delivery of water/detergent; outside of these programs, starts/stops delivery in manual mode. In the AUTO program, the quantity of water/detergent can be adjusted by pressing the button; each time the button is pressed, the set level increases, Lev1, Lev2,..... Lev Auto (delivery proportional to travel speed).
If the AUTO program is active, setting the delivery parameter will exit the program and activate manual mode.
- ▶ **CHEM-DOSE (accessory):** pressing the “water/detergent” + “brush” buttons together activates detergent quantity adjustment mode; once the chemical symbol (flask) is shown on the display, pressing the “+” and “-” buttons adjusts the level, from OFF to 0.2%, 0.3% etc. up to 7%.
- ▶ **Brush button (fig. 12, ref. 3):** inside the AUTO, ECO and APC programs, starts/stops the brushes; outside of these programs, starts/stops operation of the brushes in manual mode. In the AUTO program, pressing and holding the button (for two seconds) activates brush pressure adjustment mode; pressing the “+” and “-” buttons performs the adjustment, from 1 to 5 (VERSION WITH TWO BRUSHES ONLY). Setting the parameter exits the program and activates manual mode.
- ▶ **Attach-release brushes “CLICK-ON-OFF” (fig. 12, ref. 4):** used to automatically attach and detach the brushes. Pressing the button once after starting the machine releases the brushes, pressing it a second time activates automatic brush attachment. The button is only active when all the functions are deactivated (suction motor and brushes); the same button can be used to navigate the [“Technical Menu”](#).

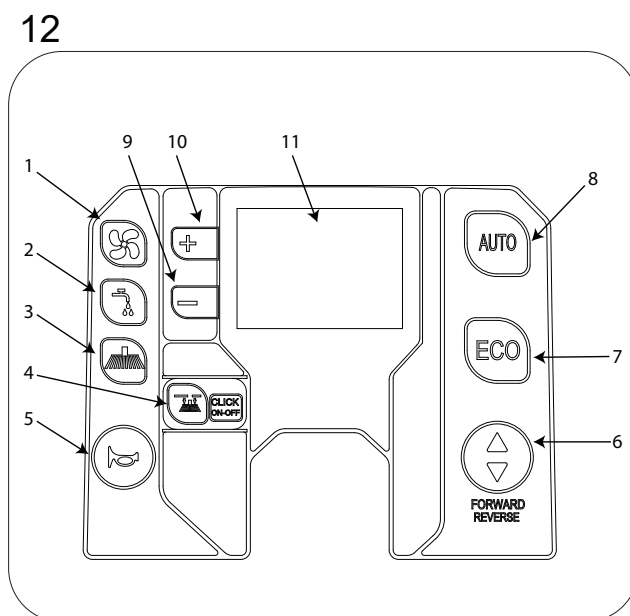

- ▶ **Horn button (fig. 12, ref. 5):** Press to sound the horn.
- ▶ **Forwards travel button (fig. 12, ref. 6):** selects the machine's travel direction; when selecting reverse gear, the display shows the letter "R" and the buzzer sounds intermittently.
- ▶ **ECO program button (fig. 12, ref. 7):** all the functions are activated in "ECO" mode: brush pressure, water/detergent flow-rate, brush speed and suction motor speed. In this program, energy consumption is reduced and the machine emits less noise.
- ▶ **AUTO program button (fig. 12, ref. 8):** all the functions are activated in "AUTOMATIC" mode: brush pressure, water flow-rate and detergent delivery are preset by the manufacturer, however can be modified from the ["Technical Menu"](#).
- ▶ **"+ , -" buttons (fig. 12, ref. 9-10):** these are used to set travel speed, or increase or decrease the user parameters.
- ▶ **Display (fig. 12, ref. 11):** displays the remaining battery charge, expressed as a percentage, the logo of the active functions, "hour counter" - the machine operating hours, the set travel speed and any alarms, see chapter ["Alarms on the display"](#).

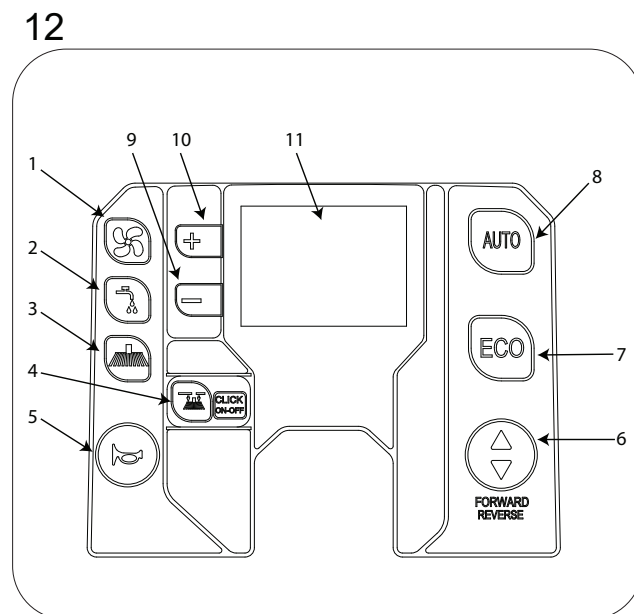

Working

- ▶ Sit correctly in the seat.
- ▶ Turn the main switch to position “1”.
- ▶ Select the direction of travel with the direction selector.
- ▶ Select the AUTO or ECO program.
- ▶ Press the accelerator pedal to move off and start work.

Some useful tips to get the most from your scrubber drier

In the event of particularly stubborn dirt on the floor, washing and drying can be performed in two separate operations.

Prewashing with brushes or pads:

- ▶ Turn the main switch to position “1”.
- ▶ Select the AUTO or ECO program.
- ▶ Press the suction motor button to stop suction.
- ▶ Press the accelerator pedal to move off and start work.
- ▶ If necessary, adjust the flow of detergent delivered to the brush, using the water/detergent button; the outlet flow must be metered in relation to the required travel speed; the slower the machine travels, the less detergent must be delivered.
- ▶ Persist when washing particularly dirty points to give the detergent time to perform its chemical action detaching and suspending the dirt and the brushes time to exert an effective mechanical action.

Drying:

- ▶ Lower the squeegee and with the suction motor on, pass over the same area washed previously. The result is equivalent to in-depth washing and subsequent ordinary maintenance will take less time.

Emptying the collection tank:

If the tank is full, the display shows the corresponding alarm, see [“Display alarms”](#); after a few seconds, the suction motor shuts down, then stop the machine and empty the tank following the instructions shown below:

- ▶ Switch off all the machine’s functions.
- ▶ Take the machine to the disposal area.
- ▶ Unhook the hose from the clip.
- ▶ Empty the tank using the hose (fig. 13, ref. 1), at the end rinse the tank with clean water.

13

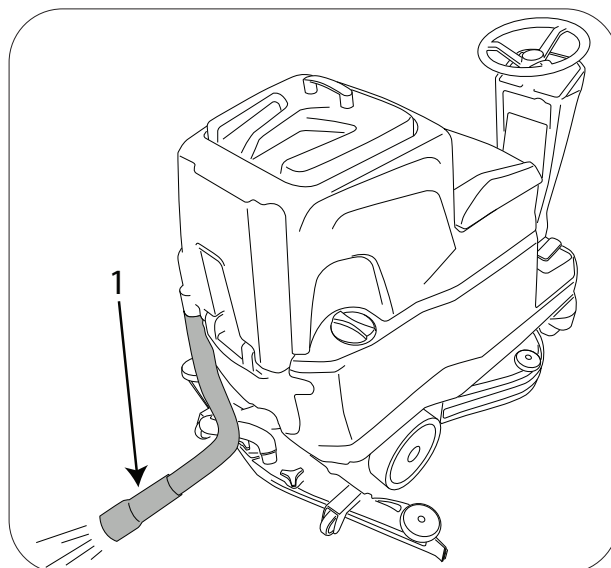

Emptying the water/detergent tank

To empty the tank, follow the instructions shown below:

- ▶ Switch off all the machine's functions.
- ▶ Take the machine to the disposal area.
- ▶ Stop the machine.
- ▶ Detach the hose (fig. 14, ref. 3) from its holder and unscrew the cap (fig. 14, ref. 1).
- ▶ Lower the hose, and open the tap (fig. 14, ref. 2) to empty the tank.

14

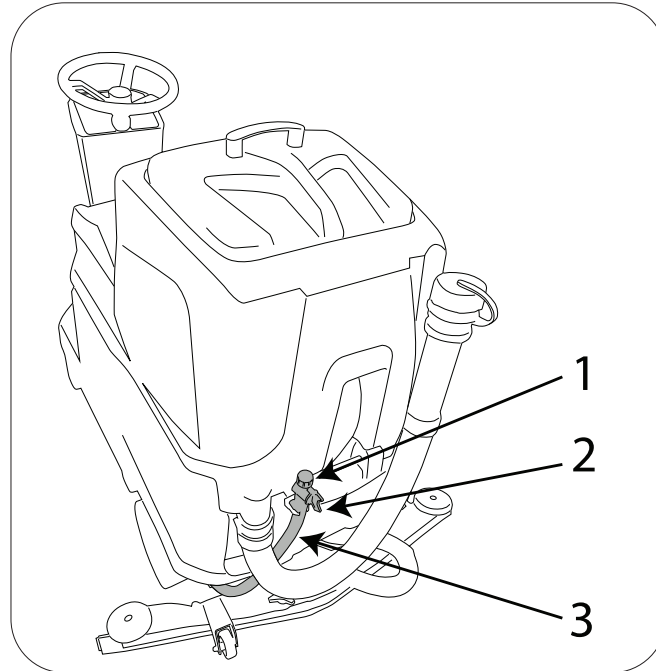

Filling the water/detergent tank

Before commencing the operation of filling the tank, unscrew the cap (fig. 15, ref. 1) and open the tap (fig. 15, ref. 2) on the hose (fig. 15, ref. 3). This sequence of steps will allow air to escape from the hose/tank and, during the course of the filling operation, enable inspection of the level of water/detergent in the tank directly from the exposed hose. Fill the tank through the opening provided (fig. 15). The machine is equipped with a graduated measuring cap that can be used to dilute the detergent inside the tank. If the tank is empty, the display shows the corresponding alarm, see [“Display alarms”](#).

With the filling operation completed, close the tap (fig. 15, ref. 2) and retighten the cap (fig. 15, ref. 1).

15

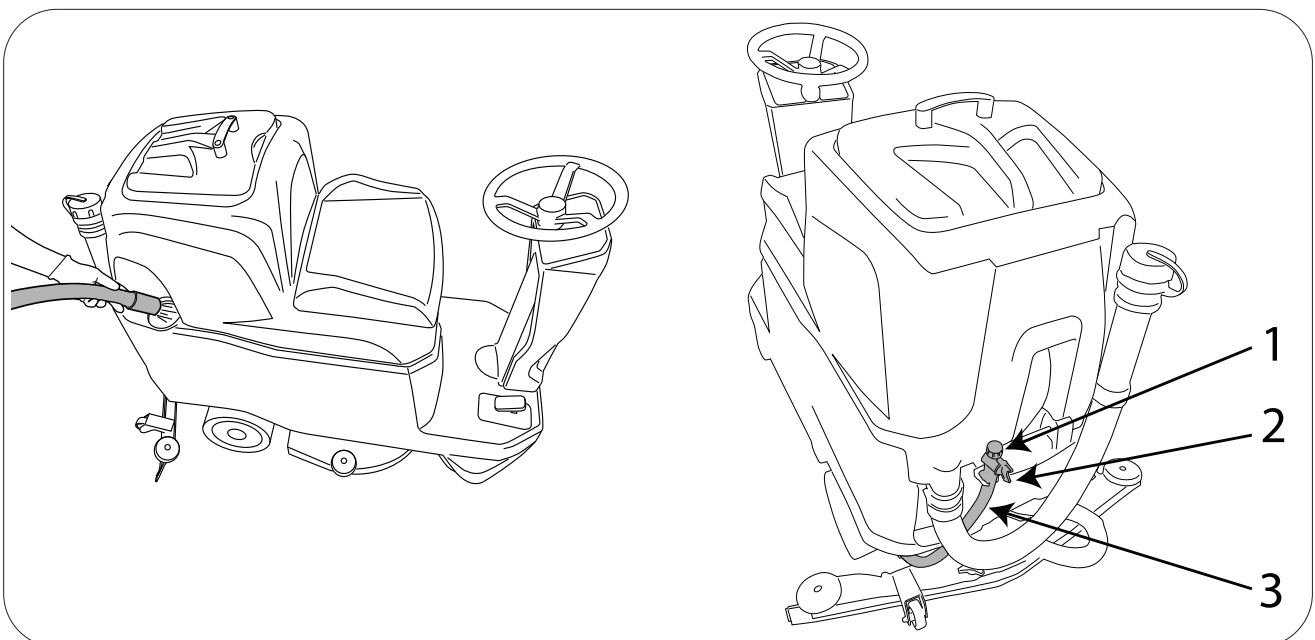

Filling the Chem-Dose tank (accessory)

Lift the dirty water tank.

Fill the tank (fig. 16) with the detergent as highlighted.

16

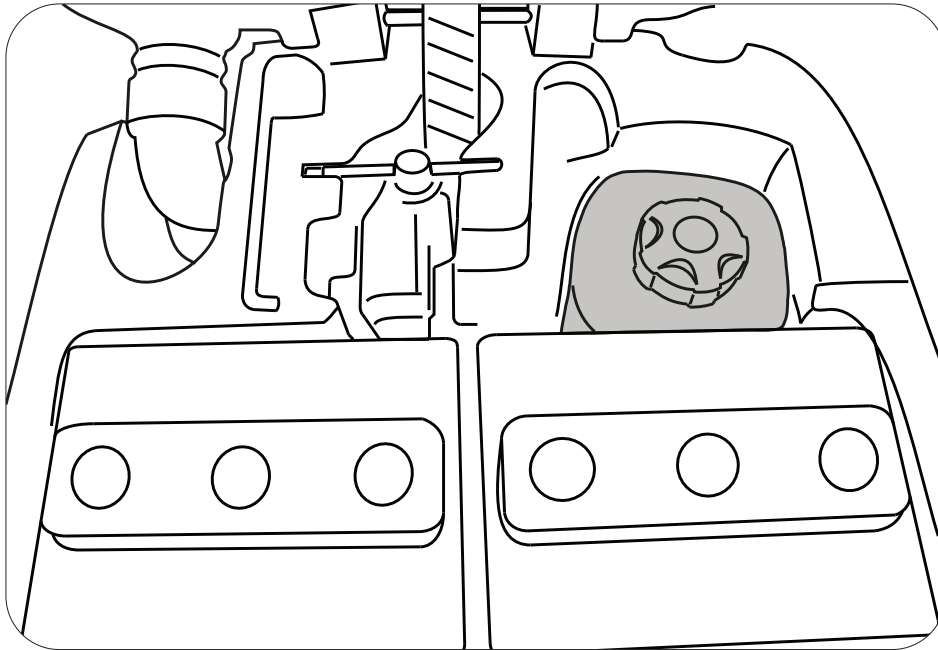

Finishing work

! IMPORTANT!

Empty the dirty water tank and recharge the batteries

When ending work, switch off the machine at the main switch. The machine does not have a parking brake as it is fitted with an electric brake, which automatically brakes the machine when the drive pedal is not pressed.

Moving the machine when not in operation

Proceed as follows to move the machine.

- ▶ Select the direction of travel.
- ▶ Press the accelerator pedal.

If the machine cannot be moved using the electric drive, the machine can be pushed after having disengaged the electric brake, see ["Pushing and pulling the machine"](#).

PERIODS OF INACTIVITY

If the machine is not used for some time, for example, on display in a showroom or stored in the warehouse for a period or more than one month, the following operations are required:

- ▶ Completely recharge the batteries before storing them. During long periods of inactivity, you should charge the batteries regularly (at least once every two months) to keep them constantly at maximum charge.
- ▶ Disconnect the batteries from the machine using the connector provided.
- ▶ Unplug the battery charger (if present) from the mains power supply.
- ▶ Remove the squeegee and brushes (or abrasive disks), wash them and put them away in a dry place (preferably in a bag or wrapped in plastic film) away from dust.
- ▶ Make sure the tanks are completely empty and perfectly clean.

! WARNING!

If the batteries are not recharged regularly as described above, they may be irrevocably damaged.

The manufacturer is not liable for any malfunctions resulting from neglect, improper and/or incorrect use.

MAINTENANCE INSTRUCTIONS

! DANGER!

Never perform any maintenance operations without first disconnecting the batteries. Maintenance of the electrical circuit and all other operations not expressly required by this manual must be performed by specialised personnel only, in compliance with current safety legislation and as described in the maintenance manual.

Maintenance - General rules

Performing regular maintenance according to the Manufacturer's instructions improves performance and extends the working life of the machine.

When cleaning the machine, observe the following precautions.

- ▶ Avoid using pressure washers. Water could penetrate the electrical compartment or motors leading to damage or short circuits.
- ▶ Do not use steam to avoid the heat warping plastic parts.
- ▶ Do not use solvents or hydrocarbon based products. These can damage the cowling and rubber components.

Cleaning the suction motor air filter

Open the dirty water tank lid, then remove the filter from its housing (fig. 17), wash it under running water or using the same detergent dispensed by the machine, then when it is dry, replace the filter in its housing.

17



Cleaning the water/detergent tank filter

To clean the filter, proceed as follows:

- ▶ Close the tap (fig. 18, ref. 1) on the front left of the machine, next to the drive wheel.
- ▶ Unscrew the filter cover (fig. 18, ref. 2), remove the filter, then wash it under running water or using the same detergent dispensed by the machine.
- ▶ Replace the filter in its housing, making sure it is correctly positioned and retighten the screw.

18

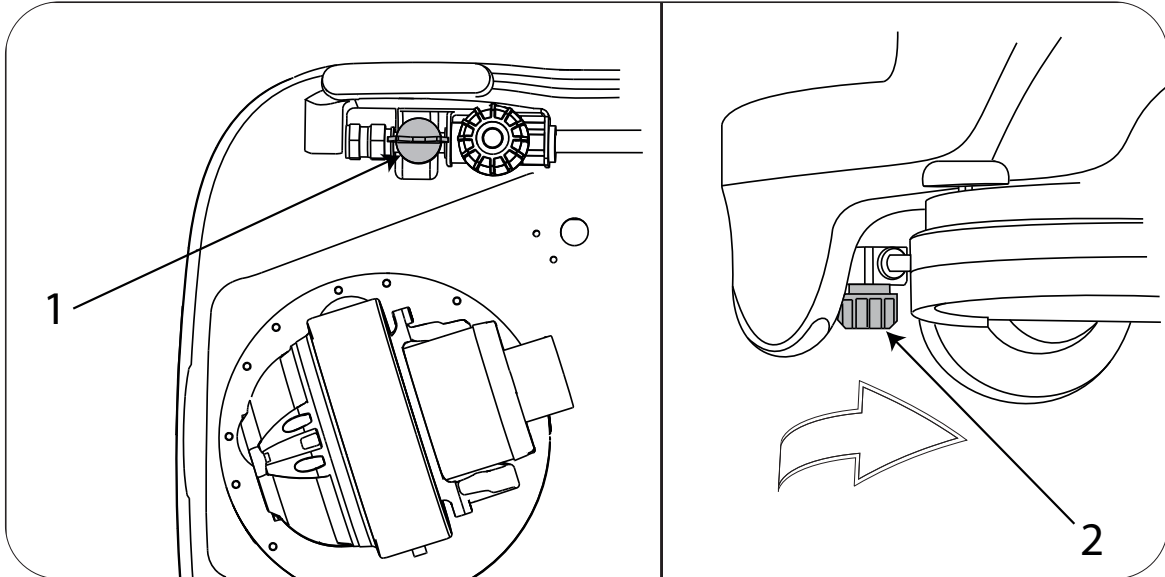

Cleaning the dirty water tank float

Open the dirty water tank lid, clean the float (fig. 19, ref. 1) situated at the front of the dirty water tank, making sure not to aim the water directly against the float; make sure it slides freely on its rod.

19

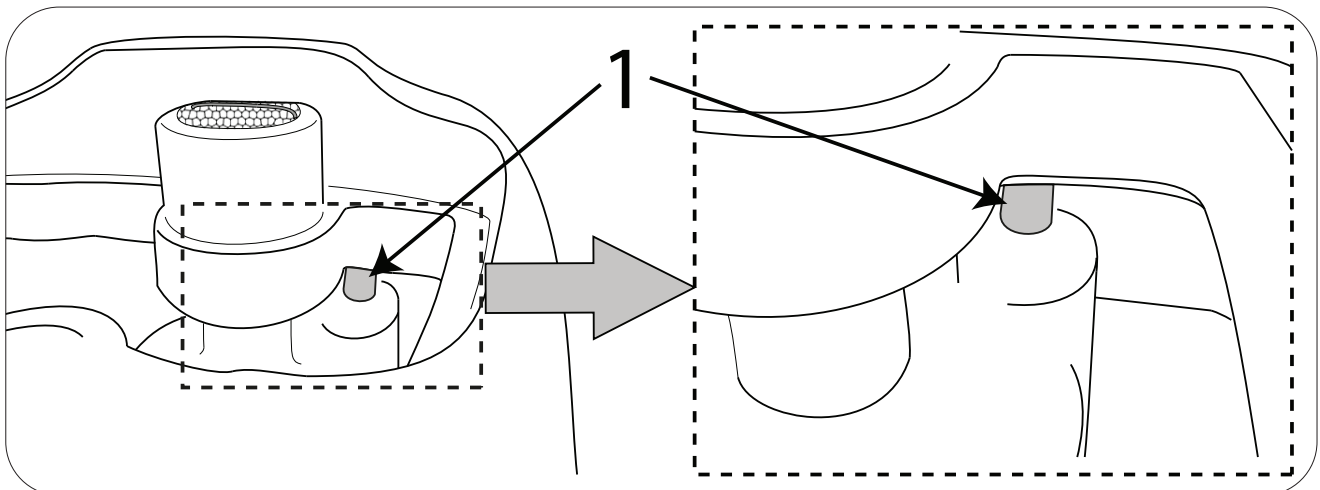

Fuses: replacing

! DANGER!

This operation must be performed with the machine switched off and the key removed.

! WARNING!

Never use a fuse with a higher amperage than specified.

! DANGER!

Do not rest the electronic board panel on the batteries, as a short-circuit may cause the batteries to explode.

If a fuse continues to blow, the fault in the wiring, boards (if present) or motors must be identified and repaired. Have the machine checked by qualified personnel.

Lift the dirty water tank, disconnect the battery wiring connector from the electrical system (fig. 20, ref. 1-2-3), lift the electronic board panel, secure it to the corner of the tank, as shown in the figure (fig. 21), then check the fuses.

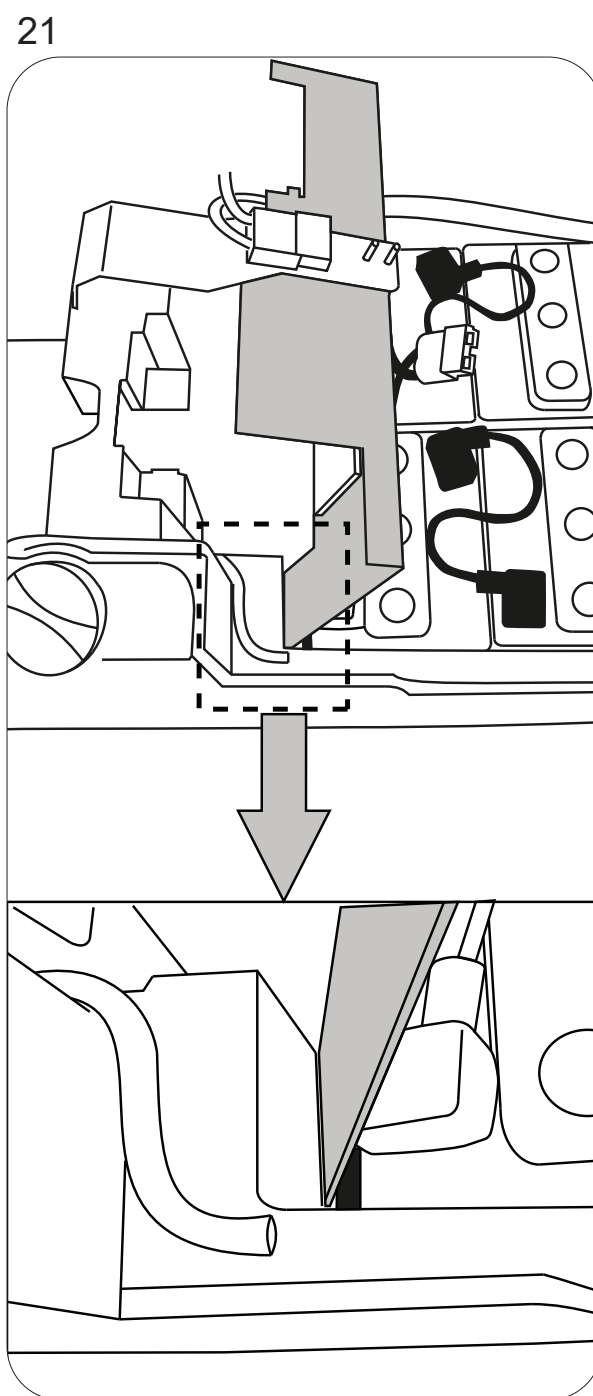
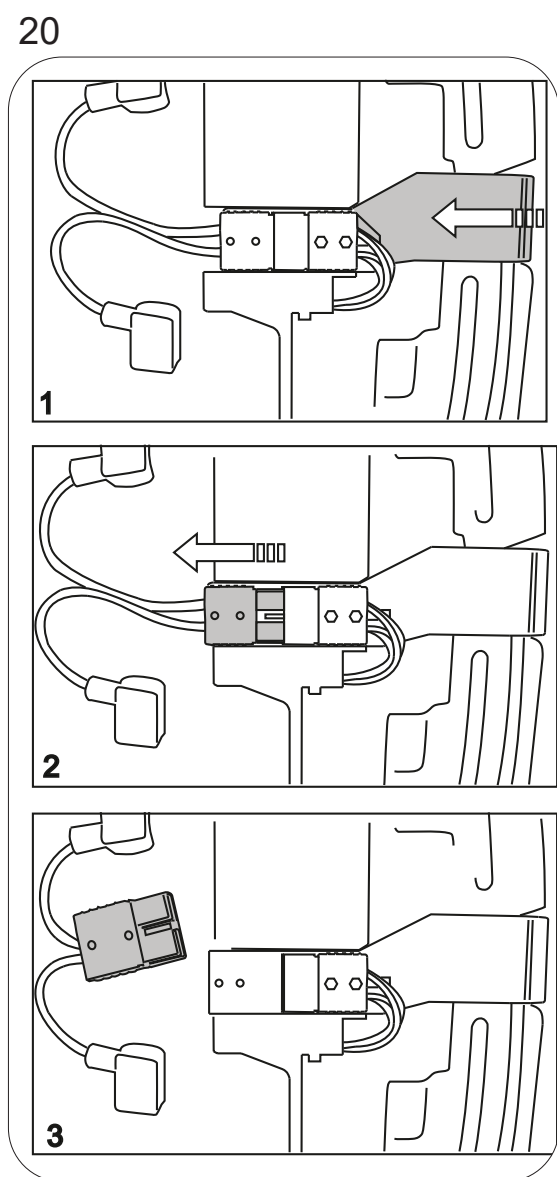

(fig. 22, ref. 1) main fuse 100A.

22

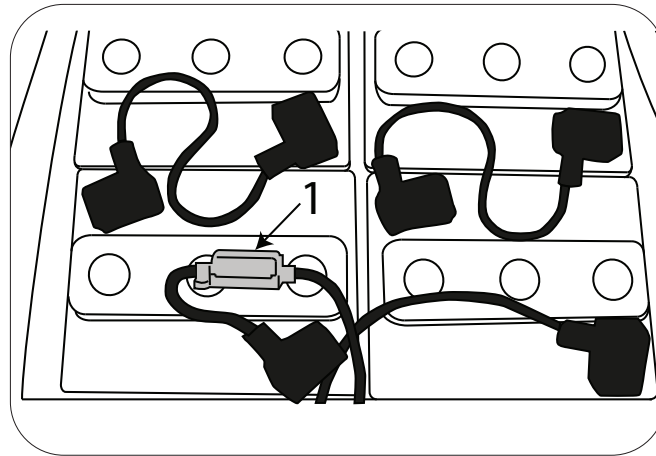

Name	Value	Function
fig.23, ref. 1	3A	SERVICE BOARD
fig.23, ref. 2	3A	DASHBOARD
fig.23, ref. 3	30A	VACUUM MOTOR
fig.23, ref. 4	30A	BRUSH MOTOR
fig.23, ref. 5	30A	BRUSH MOTOR
fig.23, ref. 6	5A	KEY SWITCH
fig.23, ref. 7	3A	BRUSH ACTUATOR
fig.23, ref. 8	3A	SQUEEGEE ACTUATOR

23

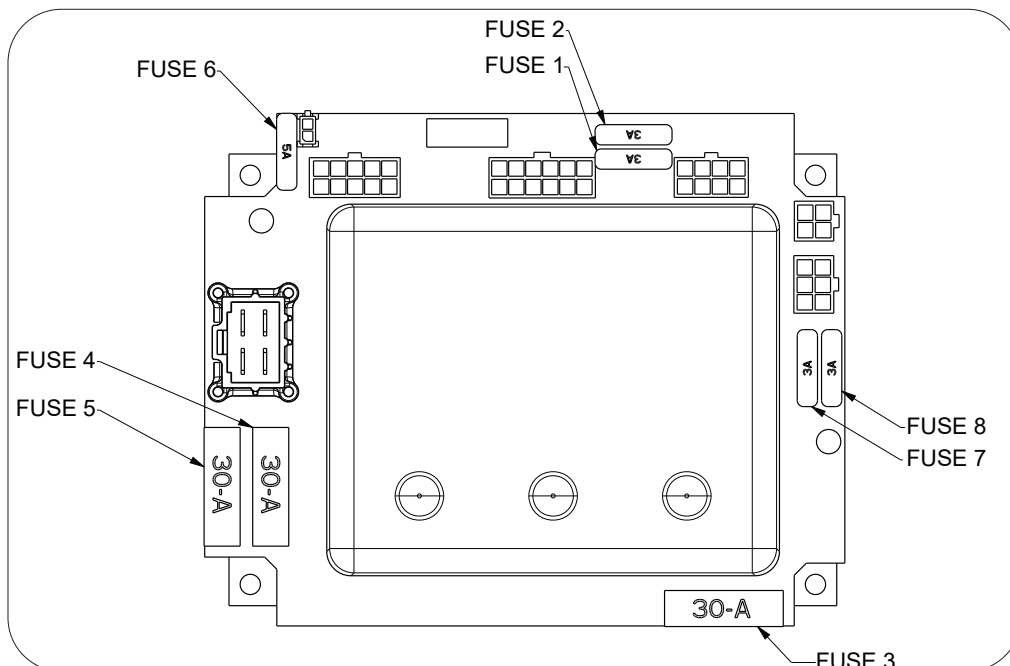

Battery maintenance and charging

! DANGER!

Do not check the batteries by sparking.

The batteries give off flammable fumes. Put out all fires and hot embers before checking or topping up the battery level.

! DANGER!

Perform the operations described below in a ventilated area.

! WARNING

When recharging the batteries, the dirty water tank must be open (rotated backwards) so as to allow correct air flow in the battery and battery charger compartment.

! WARNING!

In the case of gel batteries, use a specific charger for gel batteries only.

! WARNING!

To avoid permanent damage to the batteries, do not run them down completely.

! WARNING!

Charge the batteries as instructed in the battery charger manual.

Disconnect the connectors at the end of charging.

To avoid permanent damage to the batteries, do not run them down completely.

“OFF-BOARD” battery charger, electrical connection to the machine:

- ▶ Lift the dirty water tank.
- ▶ Press the emergency switch (fig. 24, ref. 1).
- ▶ Lift the connector (fig. 24, ref. 2-3), removing it from the two pins.
- ▶ Attach the connector to the battery charger.
- ▶ Start the recharge cycle.
- ▶ Disconnect the connectors at the end of charging.
- ▶ Reconnect the battery wiring connector to the machine connector.

24

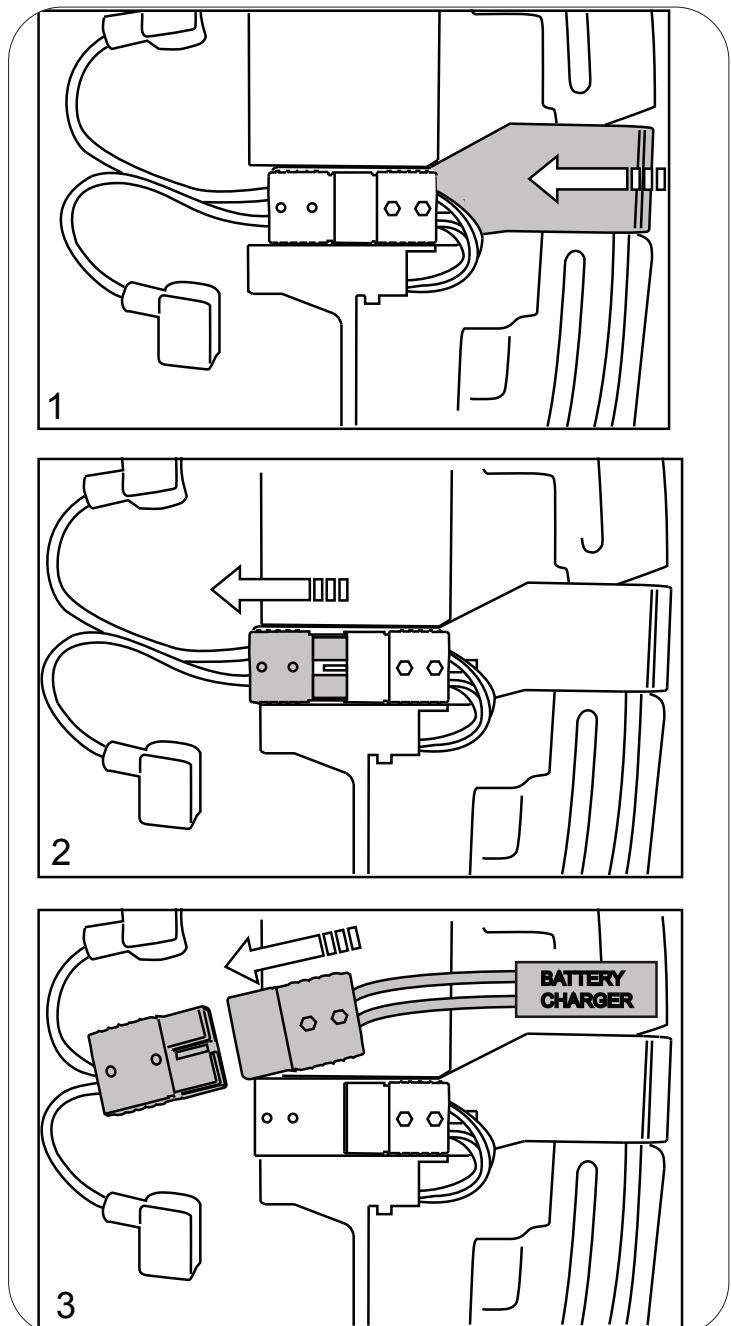

“ON-BOARD” battery charger:

- ▶ Lift the dirty water tank
- ▶ Unplug the battery charger.
- ▶ Plug the cable into the power socket (fig. 25).
- ▶ Start the recharge cycle.
- ▶ The display will show when the recharge cycle ends, see [“Display alarms”](#)
- ▶ At end of the recharge cycle, unplug the cable from the power socket.

25

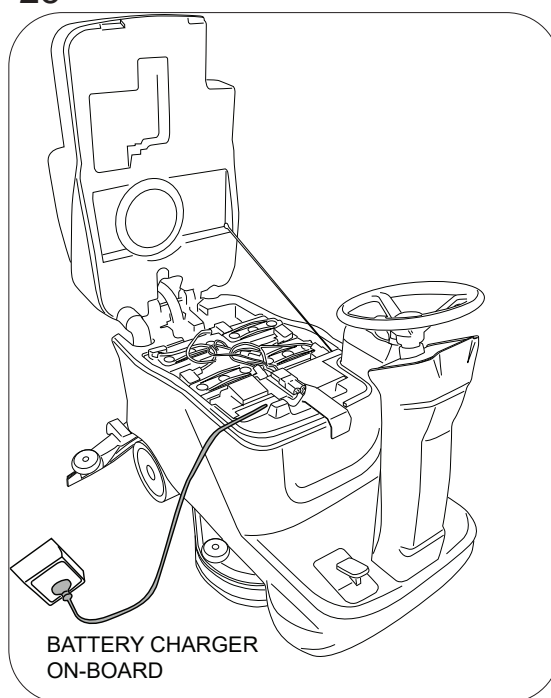

Replacing the squeegee blades

- ▶ Switch the machine on, lower the squeegee by pressing the suction motor button.
- ▶ Remove the suction hose from the squeegee (fig. 26).
- ▶ Unscrew the fastening knobs.
- ▶ Remove the squeegee from the slots on the support.

26

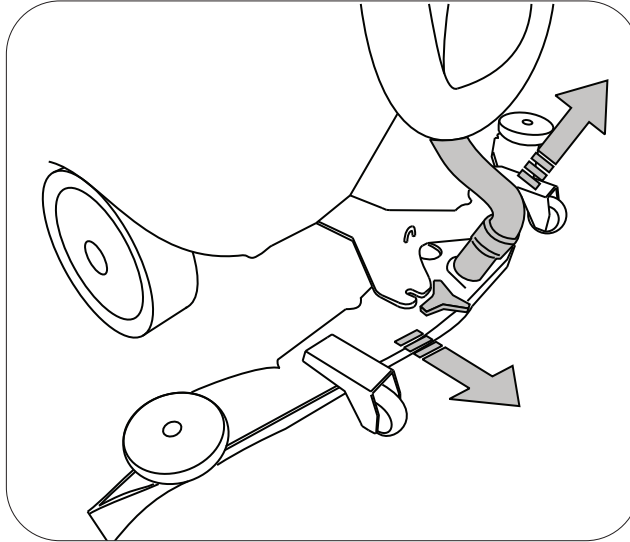

- ▶ Open the hook (fig. 27, ref. 1).
- ▶ Push the two blade pressing devices (fig. 27, ref. 2) outwards, then remove them.
- ▶ Remove the blade.
- ▶ Reuse the same blade by reversing the edge in contact with the floor until all four edges are worn out, or replace with a new blade, fitting it onto the screws on the body of the squeegee.
- ▶ Reposition the two blade pressing devices by centering the wider part of the slots on the squeegee body fastening pins, then push the blade pressing devices inwards.
- ▶ Close the hook again.
- ▶ Replace the squeegee on its support, following the instructions described previously.

27

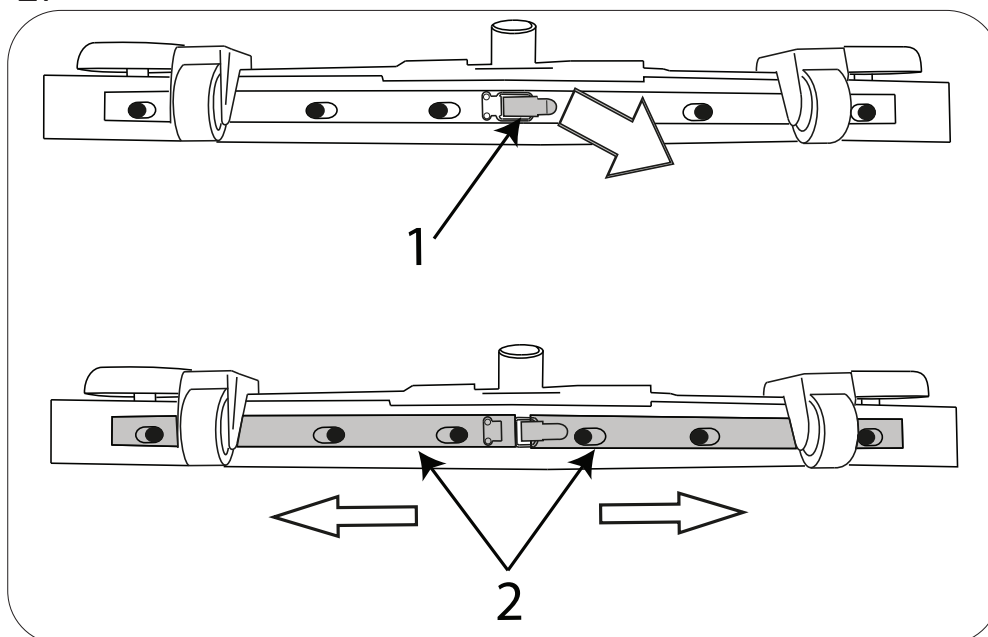

Pushing and pulling the machine:

When the electric drive cannot be used, the machine can be easily pushed or pulled by removing the lock pin and turning the lever (fig. 28) clockwise, so as to release the electric brake.

28

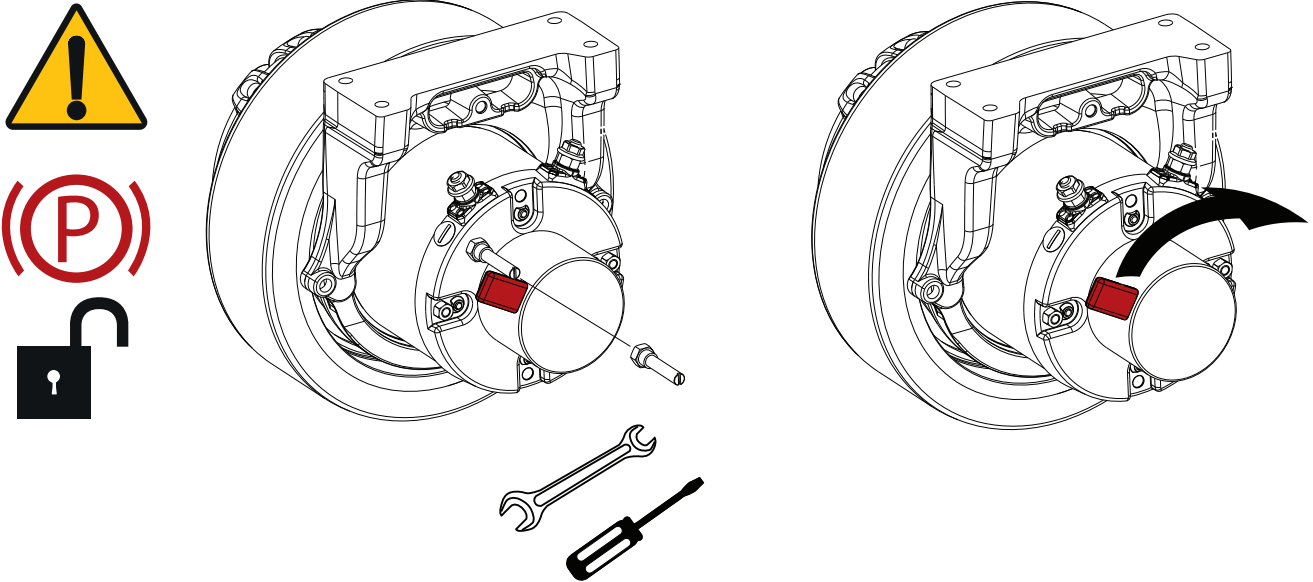

After moving the machine, set the lever back to original position and replace lock pin.

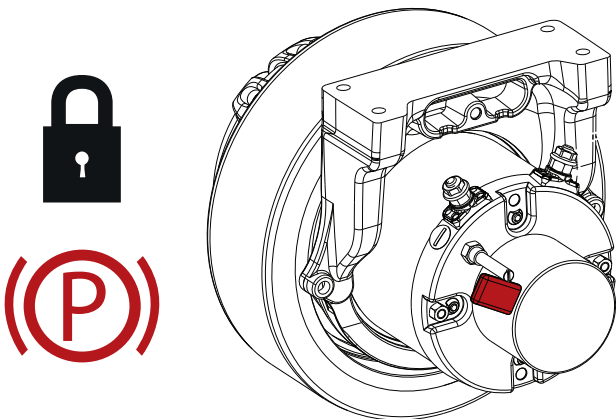

! WARNING!

If the lever is in the position where the electric brake is disengaged (lever turned clockwise), the machine's brake will be disabled.

Never start the machine with the electric brake disabled.

Periodic checks

The table below indicates the Person Responsible for each procedure.

O = Operator.

T = Trained Personnel.

Interval	Person Resp.	Key	Description	Procedure	Lubricant/ Fluid
Daily	O	1	Pad(s)	Check, flip or replace	
	O	1	Brush(s)	Check, clean	
	O	2	Squeegee	Clean, check for damage and wear	
	O	1	Scrub head skirt	Check for damage and wear	
	O	3	recovery tank	Drain, rinse, clean float shut-off screen and debris tray	
	O	4	Solution tank	Drain, rinse	
	O	5	Batteries	Charge if necessary	
Weekly	O	5	Battery cells	Check electrolyte level	DW
	O	5	Battery compartment	Check for liquid	
50 Hours	O	6	Recovery tank lid seal	Check for wear	
	O	7	Solution tank filter	Remove and clean	
2 0 0 Hours	O	5	Batteries, terminals and cables	Check and clean	
	T	8	Steering chain	Lubricate, check tension, and check for damage and wear	GL
7 5 0 Hours	T	9	Vacuum motor	Replace carbon brushes	
1 2 5 0 Hours	T	8	Propel motor	Replace carbon brushes	
	T	1	Brush motor(s)	Replace carbon brushes	

LUBRICANT/FLUID

DW Distilled water

GL SAE 90 weight gear lubricant

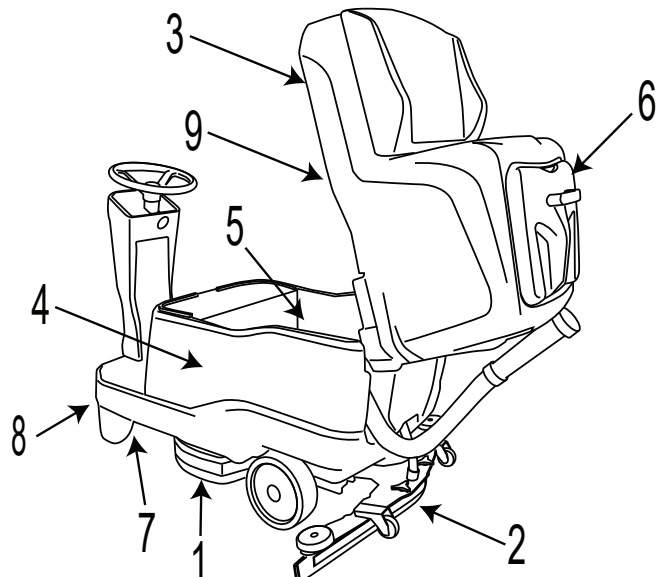

TROUBLESHOOTING

PROBLEM	CAUSE	REMEDY
The machine does not work	The batteries are disconnected	Connect the batteries to the machine
	The batteries are flat	Recharge the batteries
	Battery disconnect lever pressed	Return the lever to its correct position
The brushes do not turn	The dirty water tank is full	Empty the dirty water tank
	Blown fuse	Replace
	Faulty switch	Replace
	The batteries are flat	Recharge the batteries
	Damaged motor	Replace
	Wire detached	Check
The machine does not clean uniformly	The brush or disks are worn	Replace
No solution comes out of the detergent tank	The tap upstream of the filter is closed	Open the tap
	Damaged solenoid valve	Replace
	Dirty solenoid valve	Check
	The detergent tank is empty	Top up
	The hose delivering detergent to the brush is blocked	Unblock
	Blown fuse	Replace
Detergent flow does not stop	Damaged solenoid valve	Replace
	Damaged solenoid valve wiring	Check
The suction motor does not start	The dirty water tank is full	Empty the dirty water tank
	Blown fuse	Replace
	Faulty switch	Replace
	The batteries are flat	Recharge the batteries
	Damaged motor	Replace
	Wire detached	Check
The squeegee does not clean or has poor suction	The edge of the rubber blades in contact with the floor is worn	Replace the blades
	Blockage or damage in the squeegee or in the hose	Check
	The dirty water tank float is activated or is blocked by dirt, or is faulty	Empty the dirty water tank, check the float.
	Blockage in the suction hose	Check
	The suction hose is not connected to the squeegee or is damaged	Check
	Suction motor not powered or faulty	Check
The machine does not move	The batteries are flat	Recharge the batteries
	Drive wheel actuator problem	Check the alarm code shown on the display
The machine does not brake	Electromagnetic brake disengaged	Check
The batteries do not provide the normal working time	The battery poles and charging terminals are dirty and oxidised	Clean and grease the poles and terminals, charge the batteries
	The battery charger does not work or is not suitable	Check
The water/detergent drain hose does not show the level of the solution in the tank during the filling operation.	Tap on water/detergent drain hose closed	Remove the cap and open the tap
	Cap on water/detergent drain hose not unscrewed	

DISPLAY ALARMS

Alarm	Possible cause	What to do
BRUSH PROTECTOR	The brush motor has overheated. Faulty thermal protector contact on the motors. Faulty connection.	Wait for the brush motors to cool down. Replace the brush motor. Check the connection.
DRIVE PROTECTOR	The drive wheel has overheated. Faulty thermal protector contact on the motor. Faulty connection.	Wait for the drive wheel to cool down. Replace the drive wheel. Check the connection.
NO OPERATOR	The driver detection microswitch is not detecting an operator.	Sit correctly in the seat. Check the connection. Check the seat microswitch.
ACCELERATOR KEY	Incorrect start-up sequence Faulty accelerator pedal microswitch. Faulty connection.	Release the accelerator pedal during start-up. Replace the accelerator pedal microswitch. Check the connection.
WATER RESERVE	Solution tank almost empty. Stuck sensor. Faulty sensor or connection.	Fill the solution tank. Clean the level sensor. Replace the level sensor. Check the connection.
NO WATER	Solution tank empty. Stuck sensor. Faulty sensor or connection.	Fill the solution tank. Clean the level sensor. Replace the level sensor. Check the connection.
DIRTY WATER THANK	Dirty water tank full. Stuck sensor. Faulty sensor or connection.	Empty the dirty water tank. Clean the level sensor. Replace the level sensor. Check the connection.
CHEMICAL FINISHED	Chem-Dose tank empty. Stuck sensor. Faulty sensor or connection.	Fill the Chem-Dose tank. Clean the level sensor. Replace the level sensor. Check the connection.
FUNCTION BOARD NOT DETECTED	Communication with functions board interrupted. Faulty auxiliary boards.	Check the connection between the boards. Check the auxiliary boards.
BATTERY FLAT	Battery voltage less than: 20.7 V GEL/AGM - 20.3 V ACID - 22.8 V TPPL. Flat batteries.	Recharge the batteries. Replace the batteries.
BATTERY RESERVE	Battery voltage less than : 21.5 V GEL/AGM - 20.5 V ACID - 23.1 V TPPL. Flat batteries.	Recharge the batteries. Replace the batteries.
CALL SERVICE	The set number of hours for scheduled service have been reached/exceeded.	Call a service centre to arrange scheduled service.
BATTERY CHARGING	The on-board battery charger is operating, all the machine's functions are disabled.	Disconnect the battery charger
CHARGING COMPLETE	The on-board battery charger is operating, the charge is complete, all the machine's functions are disabled.	Disconnect the battery charger
ERROR FROM C.B.	Battery charger malfunction	Replace the battery charger
BATTERY NO CONNECT	Battery not connected Fuse inside the battery charger blown	Connect the battery Replace the battery charger
O.C. BRUSH	Brush motor short-circuit	Replace the brush motor
BRUSH FUSE	Brush motor fuse blown	Replace the fuse

DISCONNECT EMERGENCY	Electronic board communication problem	Press the emergency switch and reset it after 10 seconds. If following this procedure, the "update software" message is shown on the display, do not switch the machine off, but rather wait for the procedure to end.
DRIVE BOARD DISPLAY ALARMS		
DRIVE BOARD TEMPERATURE	Board temperature between -10°C and +80°C. Excessive vehicle effort. Electric brake engaged.	Cool or heat the board. Do not overwork the machine on long ramps. Check the electric brake.
ACCELERATOR FAULT	Faulty potentiometer connections. Faulty potentiometer. Incorrect potentiometer type setting.	Check the connection. Replace the potentiometer. Set the correct potentiometer.
SPEED FAULT	Speed signal connections interrupted. Faulty functions board.	Check connection between functions board and drive board. Replace functions board.
DRIVE BOARD U.V.	Battery voltage less than 17 V. Connection error between batteries and controller.	Charge or replace the batteries. Check battery connection.
DRIVE BOARD O.V.	Battery voltage over 31 V. Machine moving with battery charger connected. Faulty battery connection.	Check or replace the batteries. Disconnect the battery charger. Check battery connection.
RELAY FAULT	Faulty relay. Faulty drive board.	Replace the drive board.
INPUT FAULT	Emergency input activated on the drive board. Key connection on the drive board.	Check connection between functions board and drive board.
HDP 10 SEC.	Accelerator pedal pressed when starting for more than 10 seconds. Potentiometer not adjusted.	Release accelerator pedal when starting the machine. Check potentiometer adjustment.
ELECTRIC BRAKE FAULT	Faulty drive board. Faulty electric brake.	Replace the drive board. Check / replace the electric brake.
PRE-CARCHE FAULT	Check electric brake short. Faulty board. MOSFET failure.	Replace the drive board.
HDP	Accelerator pedal pressed when starting. Potentiometer not adjusted.	Release accelerator pedal when starting the machine. Check potentiometer adjustment.
TRACTION DRIVE FAULT	Drive motor short Drive motor connection short. Faulty board.	Check / replace the drive motor. Check motor connections. Replace the drive board.
DRIVE BOARD FAULT	Faulty drive motor connection. Faulty board.	Check motor connection. Replace the drive board.
DRIVE BOARD POWER SUPPLY	Battery not connected. Faulty battery connection.	Connect battery cables. Check battery cables
OVERCURRENT	Excessive machine effort. Drive motor damaged.	Do not overwork the machine on long ramps. Check / replace the drive motor.
TRACTION ALARM	Drive system problem	Wait a few seconds with the machine on until the correct message is shown on the display.

TECHNICAL MENU

Enter the menu by pressing “+” and “-” together when no functions are active.

The “+” button increases the selected parameter or the variable relating to the selected parameter.

The “-” button increases the selected parameter or the variable relating to the selected parameter.

The “Attach-release brushes” button selects the parameter to be set and confirms the entered variable.

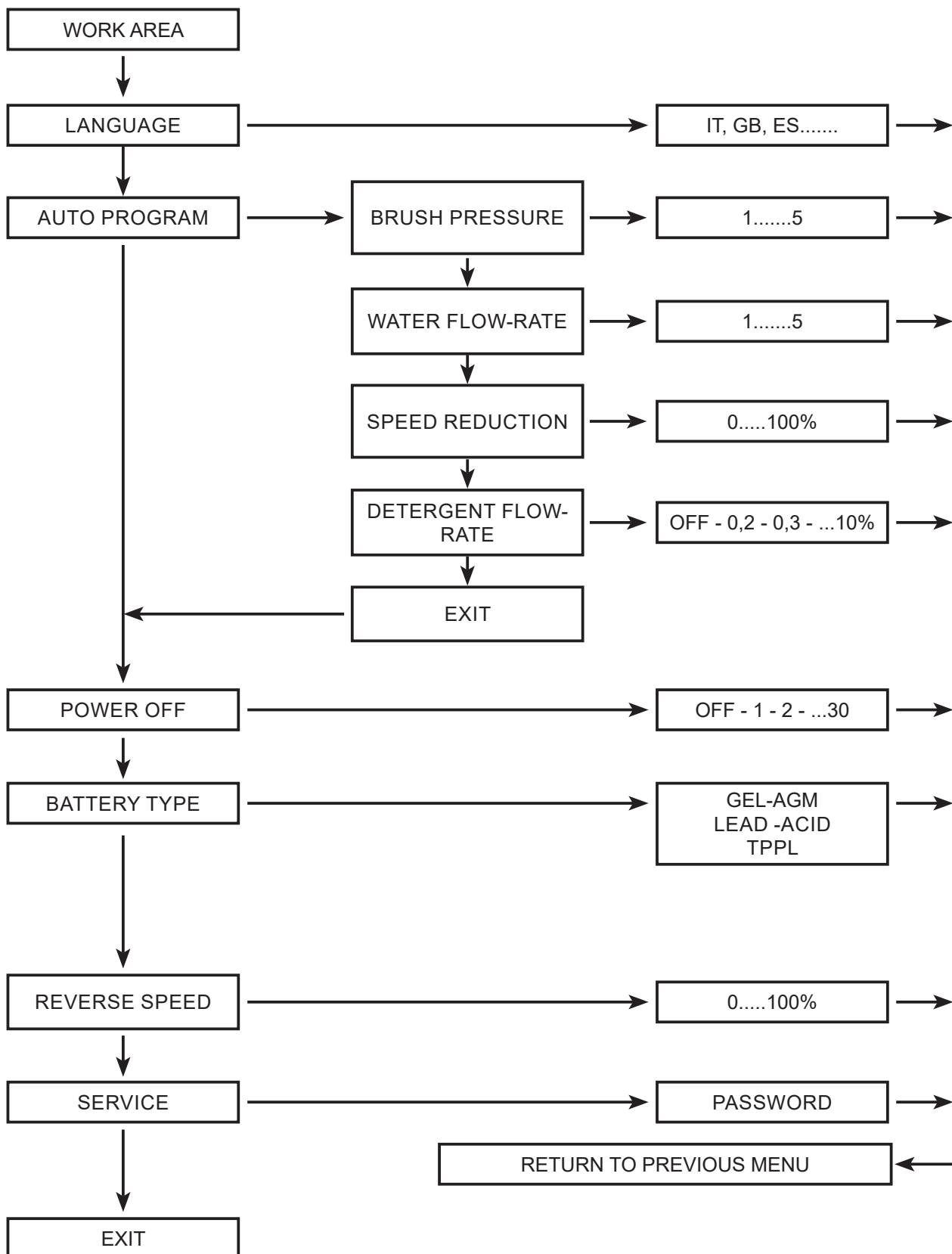

RECOMMENDED SPARE PARTS

T581 60cm	
Part Number	Description
9017813	BLADE, SQGE, FRONT, 1020L, LINATEX [STANDARD]
9017814	BLADE, SQGE, REAR, 1020L, LINATEX [STANDARD]
9017801	BLADE, SQGE, FRONT, 1020L, LATEX [OPTION]
9017804	BLADE, SQGE, REAR, 1020L, LATEX [OPTION]
9017806	BLADE, SQGE, FRONT, 1020L, PYU [OPTION]
9017811	BLADE, SQGE, REAR, 1020L, PYU [OPTION]
9017729	BRUSH ASSY, DISK, SCB, 30CM, 3-LUG, PYP [STANDARD]
SPPV01514	BRUSH ASSY, DISK, SCB, 30CM, 3-LUG, PYP, SOFT [OPTION]
9017731	BRUSH ASSY, DISK, ABR, 30CM, 3-LUG, 120 GRIT [OPTION]
9017735	DRIVER ASSY, PAD, 30CM [OPTION]
9018499	BLADE, SQGE, SIDE, RH, URE
9018500	BLADE, SQGE, SIDE, LH, URE
9017841	FLAP, CENTER, BRUSH
9018509	MOTOR, VACUUM, 24VDC
9017687	BRUSH, CARBON, VAC FAN
9017799	ISOLATOR, VAC FAN
9017843	MOTOR, BRUSH, 24VDC
9017822	CIRCUITBOARD, DRIVE
9017686	BRUSH KIT, CARBON, BRUSH MOTOR [4 PC]
9017784	BRUSH, CARBON, TRANSAXLE MOTOR
9018401	GASKET, MOTOR, VACUUM
9017785	FILTER, MOTOR, VAC FAN
9017786	HOSE ASSY, RECOVERY
897466	SCREEN, FILTER
9017790	SENSOR, LEVEL, LIQ
9017793	HOSE ASSY, DRAIN
9017794	CAP KIT, DRAIN HOSE, RECVY
9017795	SENSOR, POSITION, DRIVE
9017718	VALVE, WATER, SOLENOID, 24VDC
9017800	TIRE, SOLID, PYU
9017802	CAP KIT, DRAIN PLUG W/GASKET
9017805	ACTUATOR, BRUSH HEAD, 24VDC
9017803	ACTUATOR, SQGE, 24VDC
9017807	DRIVE ASSY, WHEEL
9017808	BRAKE ASSY, W/LEVER, COMPLT
9017809	WHEEL, SCRBR, 250MM X 60MM
MEVR00644	FUSE 30A
MEVR01132	FUSE 5A
9017819	FUSE 100A

MEVR00584	FUSE 3 A
9017821	CIRCUITBOARD, MAIN
9017823	CIRCUITBOARD, DISPLAY PANEL

Tennant Company

PO. Box

10400 Clean Street

Eden Prairie, MN 55344-2650

Phone: (800) 553- 8033

www.tennantco.com

Copyright © 2021 Tennant Company. All rights reserved.