

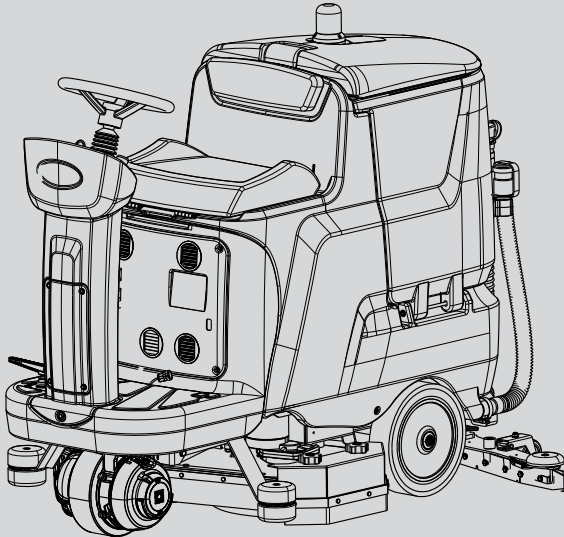

T681

BATTERY FLOOR SCRUBBER

OPERATOR'S MANUAL (EN)



Model Part No.:
LPTB03308 - SCRUBBER [T681 70CM,CD,PD,ANZ]



ANZ



To view, print or download
the parts manual, visit:
www.tennantco.com/manuals

www.tennantco.com

PLDC04602
Rev. 04 (04-2024)

TABLE OF CONTENTS

IMPORTANT SAFETY PRECAUTIONS	3
SAFETY SYMBOLS	6
TECHNICAL SPECIFICATIONS	7
MACHINE DIMENSIONS	8
GENERAL INFORMATION	9
Purpose of this manual	9
Identifying the machine	9
Documentation provided with the machine	9
TECHNICAL INFORMATION	10
General description	10
Main parts of the machine.....	10
Control panel.....	11
Accessories.....	12
HANDLING AND INSTALLATION	13
Lifting and transporting the palletized machine.....	13
Inspection on delivery	13
Unpacking	13
Batteries.....	14
WET batteries, preparation:	14
Batteries: installation and connection.....	15
Selection of battery charger	16
Fitting the squeegee.....	16
Squeegee adjustment	16
Fitting the brush/pad drivers.....	17
Fitting the brushes (Cylindrical Brush Model)	18
Filling the detergent tank.....	18
Chem Dose (accessory).....	19
PRACTICAL GUIDE FOR THE OPERATOR	20
Clothing and equipment	20
Before starting the machine	20
Preparing the machine for work	20
Working	20
Dual wash	22
Picking up water (without washing).....	22
During operation of the machine.....	22
Emergency stop button	23
Detergent solution tank empty indicator.....	23
Dirty water tank full indicator	23
Battery charge indicator	23
Emptying the dirty water tank.....	24
Emptying the solution tank.....	24
Emptying the Cylindrical Brush Model bin.....	24
Removing the the brush/pad drivers	25
Moving the machine when not in operation.....	25
MAINTENANCE INSTRUCTIONS	26
Maintenance - General rules.....	26
Cleaning the suction motor air filter.....	26
Cleaning the dirty water tank sensor.....	26
Cleaning the solution tank filter	26
Fuses: replacing.....	27
Battery maintenance	27
Checking the electrolyte level of WET batteries.....	27
Recharging the batteries	27
Battery charger error codes	28
Battery: removal	28
Replacement of Brushes and Pads.....	29
Replacing the squeegee blades.....	29
Periodic checks	30
PERIODS OF INACTIVITY	30
TROUBLESHOOTING	31
DRIVE WHEEL PCB ALARMS	32
ALARMS/WARNINGS DISPLAYED	32
RECOMMENDED SPARE PARTS	33

IMPORTANT SAFETY **PRECAUTIONS**

Parts of the text requiring special attention are printed in bold and preceded by the symbols illustrated and described below.



! DANGER:

Indicates the need for care in order to avoid serious consequences that could lead to the death of personnel, or to situations representing a possible health and safety hazard.

! ATTENTION:

Indicates the need for care in order to avoid serious consequences that could involve harm being done to the machine or to the workplace, or lead to economic losses.



! DANGER: If lead-acid (WET) batteries are installed in the machine, keep sparks, flames and smoking materials away from the batteries. Explosive gases can escape during normal use, particularly when recharging the batteries.



! DANGER: If lead-acid (WET) batteries are installed in the machine, charging the batteries produces highly explosive hydrogen gas. Lift the dirty water tank during the entire battery charging cycle and only perform the procedure in well ventilated areas away from naked flames.



! DANGER: Never use the machine to clean up flammable or explosive liquids (e.g. petrol, fuel oil, etc.), acids or solvents (e.g. paint solvents, acetone etc.) even if diluted.



! DANGER: Never pick up burning or incandescent objects.



! DANGER: Do not spray flammable liquids.

! ATTENTION: the machine may be equipped with technology that communicates automatically over a mobile phone network. If the machine must operate in places where the use of mobile phones is forbidden due to problems of interference with instrumentation, contact the manufacturer for information on how to deactivate the mobile communication functionality.

! ATTENTION: If particularly strong magnetic fields are present, assess their possible effect on the control electronics.

! ATTENTION: make certain that the electrical specifications of the machine (voltage, frequency and power consumption) indicated on the data plate are compatible with those of the mains electricity supply.

Do not use the machine:

- without having read the operating and maintenance manual.
- without having been trained in its use.
- without having been specifically entrusted with its use.
- if legally under age.
- if the machine is not working properly.
- if the brake is disabled.
- in places without adequate lighting.
- in explosive environments.
- on public roads.
- outdoors: the machine must be used only indoors.
- where there is dirt that can be harmful to health (dust, gas, etc.).
- where there is danger of falling objects, unless the machine is equipped with an overhead protective structure.

Clothing and equipment:

- Wear safety shoes with non-slip soles.
- Wear protective eyewear or visor and safety garments.
- Depending on the surface being cleaned and on the environment, the protective measures necessary for atomized sprays include respiratory masks with class FFP2 or equivalent or higher protection.

Before starting the machine:

- Check that the machine is not damaged.
- Check the operation of the brake.
- Check that all safety devices are in place and operating correctly.

When using the machine:

- The machine must be operated by one person only.
- Be careful to follow the safety regulations of the particular workplace regarding wet floors. When necessary, place safety signs on the wet floor while using the machine
- Park the machine on a level surface.
- Do not allow children to play on or near the machine.
- Consider the type of building in which the machine is to be used (e.g. pharmaceutical/chemical plant, hospital, etc.) and observe the internal safety regulations and conditions to the letter
- The machine must not be used for purposes other than those expressly intended.
- The machine is intended for commercial use,

for example in hotels, schools, hospitals, factories, shops, offices and business premises generally. Do not use for other purposes.

- The machine can be used only indoors.
- The machine must be stored only indoors.
- Do not allow the machine to be used as a toy.
- The machine is not designed to tow or be towed.
- Never rest objects of any significant weight on the machine, for whatever reason.
- Never obstruct the air inlet and release vents.
- Never remove, modify or circumvent safety devices.
- The machine has been designed for use with detergents supplied or recommended by the manufacturer. The use of other detergents or chemicals may jeopardise the safety of the appliance.
- When using floor cleaning products, follow the instructions and warnings on the labels of the bottles.
- Do not use detergents that may produce dangerous reactions, vapours, heat, etc.
- During use, atomized spray may form. Inhaling this atomized spray can be harmful to health.
- Work providers must conduct a risk assessment in order to specify the necessary protective measures relating to the formation of atomized sprays, depending on the surface being cleaned and the environment. Masks with class FFP2 or equivalent or higher protection are suitable for protecting against the inhalation of atomized spray.
- Keep hands away from moving parts.
- In the case of malfunction and/or faulty operation, turn the machine off immediately (disconnect from the batteries/mains power supply) and do not tamper with it; contact a service centre approved by the manufacturer.
- The machine is designed to operate in temperatures between +4°C and +40°C. It can be stored in temperatures between +0°C and +50°C when not in use.
- The machine is designed to operate at relative humidity levels between 30% and 95%.
- The machine can operate at altitudes up to 2000 m maximum.
- Do not use the machine to clean surfaces on slopes or gradients steeper than indicated on the data plate.
- Do not operate the machine on slopes or gradients steeper than indicated on the data plate.
- When using the machine on gentle gradients, do not move transversely across the slope, but keep the machine on a line parallel to the direction of the incline, manoeuvring carefully

and without making U-turns.

- The machine must not be used by persons (including children) with diminished physical, sensory or mental capabilities, or lack of experience and knowledge, unless they are supervised by a person responsible for their safety and have received instruction in the use of the machine.
- Never use the machine to transport people or goods or for towing.
- Do not wear jewellery, watches, ties or other items.
- The operator must always use Personal Protective Equipment: protective apron or overalls, non-slip waterproof shoes, rubber gloves, protective eyewear and ear defenders, and mask for protection of the respiratory airways.

Before leaving the machine or before maintenance:

- Park the machine on a flat, level surface.
- Turn off the machine and remove the ignition key.

When performing maintenance:

- All operations must be carried out in conditions guaranteeing adequate visibility and lighting.
- Disconnect the machine from its electrical power source: in the case of mains powered models, unplug the power cable from the socket; in the case of battery powered models, disconnect the batteries.
- The operator must always use Personal Protective Equipment: protective apron or overalls, non-slip waterproof shoes, rubber gloves, protective eyewear and ear defenders, and mask for protection of the respiratory airways.
- Do not wear jewellery, watches, ties or other items.
- Do not push or tow the machine without an operator sitting in the driving seat and able to control the steering wheel.
- Disconnect the batteries before starting any maintenance work.
- Protect the batteries from impurities such as metal dust.
- Take care when handling battery acid, and avoid contact. In the event of battery fluid leakage, do not touch the fluid and observe the following precautions: Contact with the skin can cause irritation; wash with soap and water. Inhalation of vapours can cause irritation to the airways; stay out in the open air and consult a doctor. Contact with the eyes can cause irritation; wash the eyes immediately, flooding with water for at least 15 minutes, and consult a doctor.
- Never rest tools on the batteries as they could

cause short circuits leading to explosions.









- Always use the battery charger accompanying the machine (if supplied), or if not, a product with specifications as recommended in the technical data.
- Installation of the battery should be entrusted to a TENNANT approved service technician.
- Inspect the power cable of the battery charger periodically to ensure that it is not damaged; in the event of damage being discovered, the appliance cannot be used. Replacement of the cable should be entrusted to a TENNANT approved service technician. Detach both connections of the battery charger (AC side and DC side).
- Do not tug at the battery charger cable to disconnect it from the socket: grip the plug firmly and pull.
- Never wash the machine with water jets.
- Cleaning and maintenance operations that can be performed by the user must not be entrusted to children unless under supervision.
- All repairs must be carried out by a TENNANT approved service technician.
- Use only original accessories and spare parts supplied exclusively by the manufacturer, as only these are able to guarantee safe and troublefree operation of the machine.
- Never use parts removed from other machines or from other kits.

When the machine is to be loaded onto or unloaded from a vehicle:

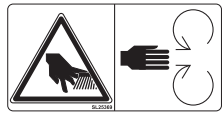
- Empty the tanks before loading the machine.
- Raise the scrub head and remove the squeegee from the machine.
- Do not drive the machine on a slippery ramp.
- Take particular care when operating the machine on ramps.
- Turn off the machine and remove the ignition key.
- Lock the wheels of the machine.
- Use straps to anchor the machine.

KEEP THESE INSTRUCTIONS SAFE.

SAFETY SYMBOLS

	<p>WARNING! RISK OF CUTTING</p>
	<p>WARNING! RISK OF CRUSHING LIMBS</p>
	<p>WARNING! RISK OF ABRASION</p>
	<p>MAXIMUM SLOPE</p>
	<p>OPERATOR MANUAL, INSTRUCTIONS FOR USE</p>
	<p>READ THE OPERATOR'S MANUAL</p>
	<p>DIRECT CURRENT SYMBOL</p>
	<p>INSULATION CLASS: THIS CLASSIFICATION ONLY APPLIES TO BATTERY POWERED MACHINES.</p>
	<p>EXTERNAL BATTERY CHARGER CONNECTION POINT.</p>

TECHNICAL SPECIFICATIONS

			70cm Disk	85cm Disk	70cm Cylindrical Brush Model
Cleaning width		mm	700	850	700
Squeegee width		mm	942	1090	1090
Cleaning capacity per hour		m ² /h	4200	4920	4680
Number of brushes		no.	2	2	2
Brush diameter		mm	340	410	150
Maximum brush pressure		kg	45	60	23,6
Brush rotation speed		rpm	215	200	880
Brush motor power		W	300	500	400
Drive motor power		W	600	600	600
Suction motor power		W	560	560	560
Machine power (P _M)		W	1824	1824	1848
Maximum speed		km/h	6	6	6
Solution tank		l	100	100	100
Dirty water tank		l	110	110	110
Front wheel diameter		mm	300	300	300
Rear wheel diameter		mm	300	300	300
Negotiable gradient		%	16	16	16
Gross weight (GVW)		kg	589	606	622
Weight of the machine in transit without batteries		kg	234	251	255
Weight of the machine in transit with batteries		kg	414	431	435
Number of batteries		no.	4	4	4
Machine voltage V _M		V	24	24	24
Individual battery capacity		Ah (5h)	185	185	185
Individual battery weight		kg	45	45	45
Supply voltage (battery recharge)	Version without on board battery charger	V	24 dc	24 dc	24 dc
Max current (battery recharge)		A	25	25	25
Mains supply voltage	Versions with on board battery charger	V	100-240 ac 50-60Hz	100-240 ac 50-60Hz	100-240 ac 50-60Hz
Max current (amperes) I		A	10	10	10
Machine dimensions		mm X Y Z	1515 1240 942	1515 1240 1090	1515 1240 1090
Battery compartment dimensions (length, width, height)		mm	589 400 380	589 400 380	589 400 380
Packed size (length, width, height)		mm	1730 960 1480	1730 960 1480	1730 960 1480
Sound pressure - Annex DD (Emission of acoustical noise) EN 60335-2-72: 2012		LpA (dBA)	75	75	68
Measurement uncertainty		K (dBA)	3	3	3
Vibration level (hand) - IEC 60335-2-72		ahv m/sec ²	≤2.5	≤2.5	≤2.5
Measurement uncertainty, k		m/sec ²	/	/	/
Vibration level (body) - IEC 60335-2-72		HBV m/sec ²	0,4	0,4	0,4
Measurement uncertainty, k		m/sec ²	0,2	0,2	0,2
Maximum water and detergent temperature		°C	55	55	55
IP degree		IP	IPX3	IPX3	IPX3

Gross weight (GVW): maximum permissible weight with the machine fully loaded and ready for use. The gross weight of the machine includes the detergent solution tank full of clean water, empty dirty water tank (half full in the case of recycling systems), empty dust bags, the hopper filled to its rated capacity, the largest recommended batteries and all accessories such as cables, hoses, detergent, mops and brushes.

Transported weight: the weight of the machine including batteries, but excluding optionals (for example, the operator's cabin, FOPS (Falling Object Protective Structure), second and third side brushes and front brush attachment), fresh water (in the case of scrubbers or combination machines) and the weight of a standard operator (75 kg). Data subject to changes without prior warning

V, I: charging / supply values

V_M, P_M: machine in average operating conditions (all functions active)

MACHINE DIMENSIONS

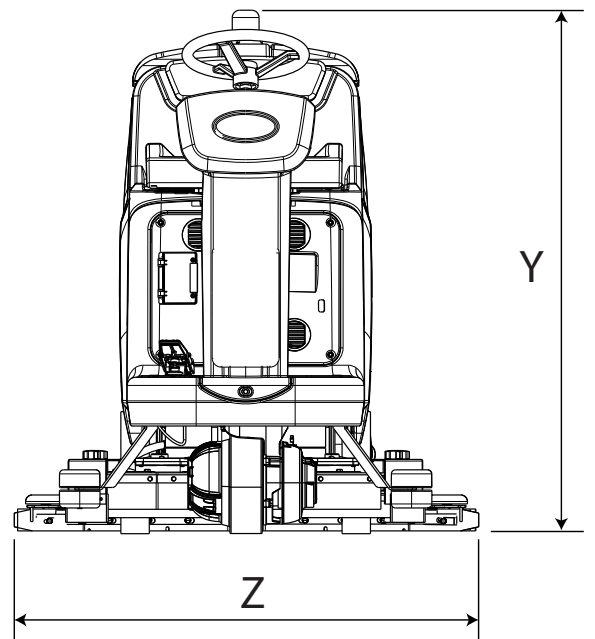
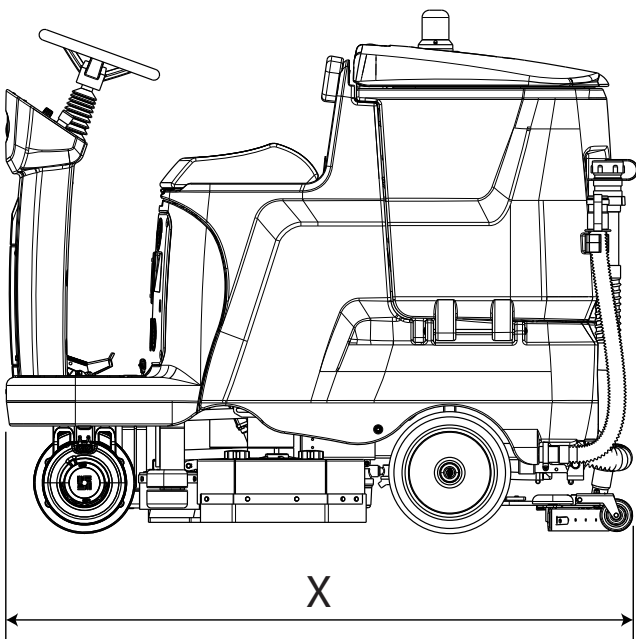

X-Y-Z: See “TECHNICAL SPECIFICATIONS” table

GENERAL INFORMATION

Purpose of this manual

This manual has been written by the Manufacturer and is an integral part of the [machine](#)¹.

It defines the purpose for which the machine has been designed and constructed and contains all the information required by [operators](#)².

In addition to this manual, which contains information for operators, other publications are available providing specific information for [maintenance personnel](#)³.

The terms “right” and “left”, “clockwise” and “anti-clockwise” refer to the forward movement of the machine.

Constant compliance with the instructions provided in this manual guarantees the safety of the operator and the machine, ensures low running costs and high quality results and extends the working life of the machine. Failure to follow these instructions may lead to injury to the operator or damage to the machine, floor and environment.

Consult the table of contents at the beginning of the manual to find the section of interest without delay.

Although your machine may differ appreciably from the illustrations in this document, the correctness and validity of the instructions contained in this manual are guaranteed.

Identifying the machine

The nameplate provides the following information:

- Name of manufacturer.
- Model.
- Serial number.
- Year of manufacture.
- Power supply voltage (charging/supply value).
- Current intensity (maximum charging value, as prescribed by the battery manufacturer).
- Gross weight.
- IP degree of protection.
- Machine voltage (in average operating conditions).
- Machine power (in average operating conditions).
- Maximum negotiable gradient.

Documentation provided with the machine

- User manual;
- Wall Chart;
- Instruction for setting the battery type on the machine;
- Instruction for setting the battery charger;

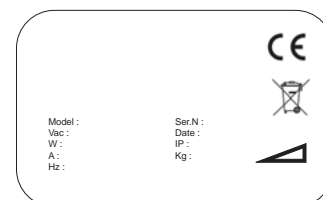

¹ The definition "machine" replaces the trade name covered by this manual.

² Persons responsible for using the machine without performing any operations requiring precise technical skills.

³ Persons with experience, technical training and a knowledge of legislation and standards, able to perform all the necessary operations and to recognise and avoid possible risks in handling, installation, use and maintenance of this machine.

TECHNICAL INFORMATION

General description

This machine is a scrubber dryer for washing and drying flat, horizontal, smooth or moderately rough, even and obstacle free floors in civil and industrial premises.

The scrubber dryer spreads a solution of water and detergent in the correct concentration on the floor and then scrubs it to remove the dirt. By carefully choosing the detergent and brushes (or abrasive disks) from the wide range of accessories available, the machine can be adapted to a wide range of combinations of types of floor and dirt.

The machine incorporates a wet vacuuming system which dries the floor immediately after washing. The drying action is produced by the suction motor, which generates a partial vacuum in the dirty water tank. The squeegee is connected to the tank, and collects the dirty water.

Main parts of the machine

The main parts of the machine are listed below:

1. Dirty water tank.
2. Solution tank.
3. Control panel.
4. Head assembly.
5. Squeegee.
6. Dirty water tank drain hose.
7. Dirty water tank lid.
8. Driver seat.
9. Batteries.
10. Steering wheel.
11. Solution tank drain hose.
12. Squeegee hose.
13. Drive pedal.
14. Solution tank filler.
15. Chem Dose tank housing.

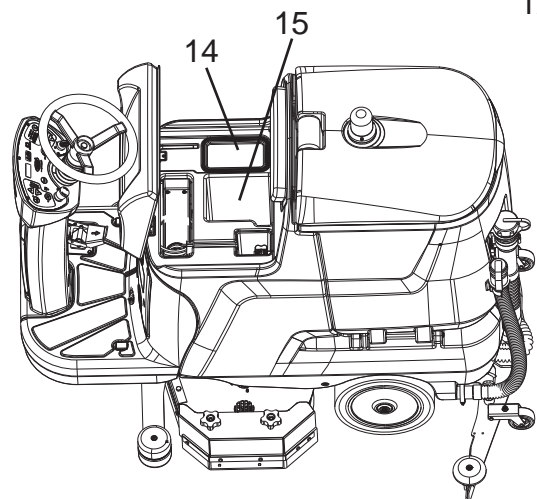
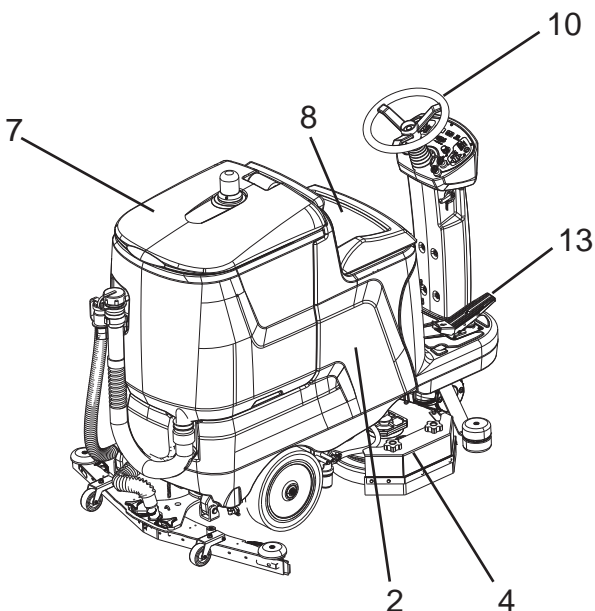
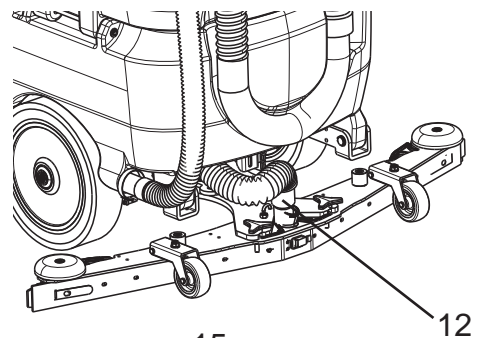
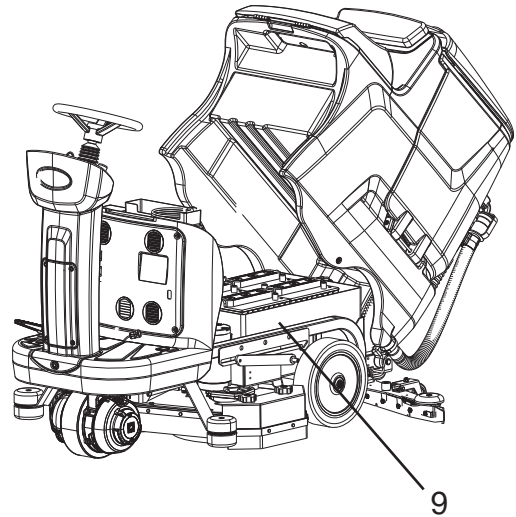
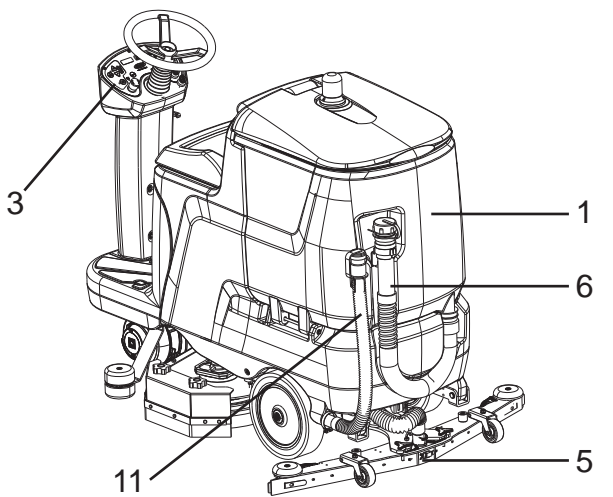

Control panel

29. Drive wheel operating status indicator Led.

The machine has the following controls and indicator lights:

16. Battery charge warning light, consisting of 4 Leds that indicate the charge level of the battery.
17. Main switch/ignition switch: connects and disconnects electrical power to and from all functions of the machine.
18. Emergency stop button: acts as a safety device.
19. Speed potentiometer: regulates the maximum speed of the machine forwards and backwards.
20. Solution flow selection button
21. Solution/detergent quantity variation buttons: used to control the flow of solution/detergent
22. Display, showing:
 - Quantity of concentrated detergent when enabled.
 - Alarm codes.
 - Hour counter.
23. Horn button.
24. Suction button: enables/disables the suction motor. Pressing and holding this button for more than five seconds, the suction motor starts running even without the operator on board the machine.
25. Brush button: enables/disables operation of the brush head.
26. Solution tank level indicator: when there is not enough water in the solution tank, the Led lights up and the brush head and solenoid valve are deactivated.
27. Dirty water tank level indicator: when the dirty water tank is full, the Led lights up and after a few seconds the suction motor is turned off.
28. Head pressure variation buttons: used to vary the pressure of the brushes on the floor.

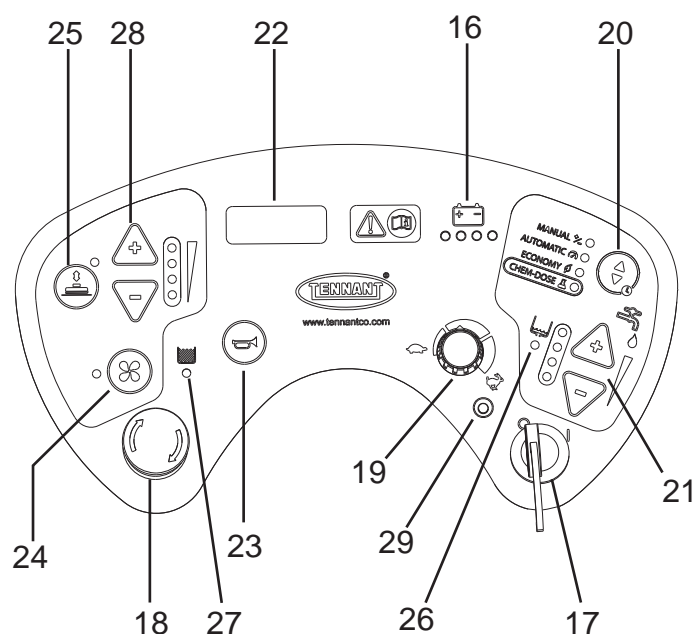

Accessories

- Bristle brushes/rollers: for washing delicate floors and polishing.
- Polypropylene brushes/rollers: for normal floor washing.
- Tynex brushes/rollers: for removing accumulated stubborn dirt on rugged floors.
- Pad drive boards: these enable use of the following disks:
 - Yellow pad, for washing and polishing marble and similar surfaces.
 - Green pad, for washing rugged floors.
 - Black pad, for thorough washing of rugged floors soiled with stubborn dirt.
- CHEM DOSE: system for controlling the flow of concentrated detergent independently from the solution tank.
- SPE CBHD3 battery charger.

HANDLING AND INSTALLATION

Lifting and transporting the palletized machine

! ATTENTION: during all lifting operations, make sure the palletized machine is firmly secured to prevent it tipping over or being accidentally dropped.

The machine must be loaded onto/unloaded from vehicles in areas with adequate lighting.

The machine is packaged on a wooden pallet by the Manufacturer. It must be loaded on to the transporting vehicle using suitable equipment (see Directive 2006/42/EEC and subsequent amendments and/or additions). At destination, it must be unloaded using similar means.

The palletized body of the machine can be lifted only with the aid of a fork lift truck. Handle with care to avoid impact and ensure the machine is not overturned.

Inspection on delivery

When the carrier delivers the machine, make sure the packaging and machine are both whole and undamaged. If the machine is damaged, make sure the carrier is aware of the damage and before accepting the goods, reserve the right (in writing) to request compensation for the damage.

Unpacking

! DANGER: when unpacking the machine, the operator must wear suitable Personal Protection Equipment (gloves, eyewear, etc.) to limit the risk of injury.

When unpacking the machine, proceed as follows:

- Cut and remove the plastic straps using scissors or nippers;
- Remove the cardboard packaging;
- Remove the bags placed inside the battery compartment and check the contents: user manual; CE certificate of conformity; quick guide; instructions for setting up the battery type on the machine; instructions for setting up the battery charger; Battery bridges with terminals; 1 x battery charge connector; 2 x key;
- Remove the metal brackets securing the front/rear wheels and the machine chassis to the pallet base.

- Remove the cover of the detergent solution filter.

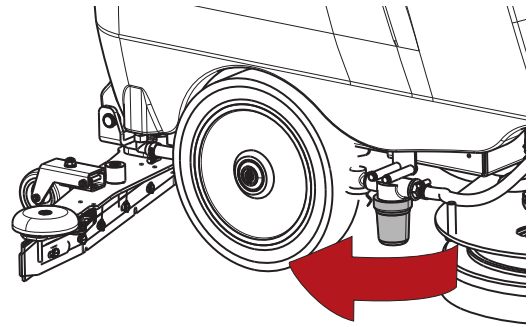

- Remove the right and left hand side flaps from the head.

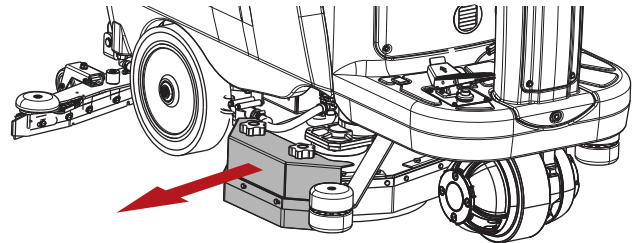

- Release the motor wheel brake, using the Allen key supplied, turning the two screws clockwise.

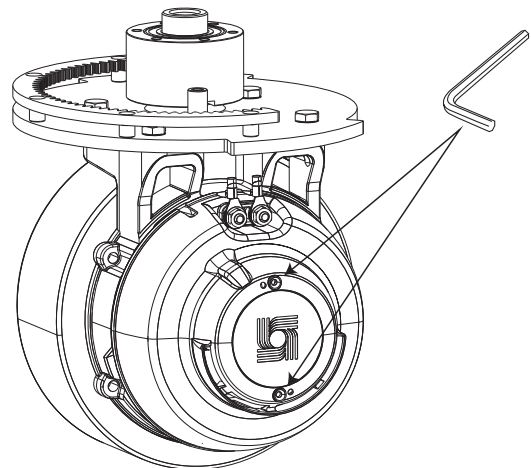

- Using a ramp, push the machine off the pallet in the reversing direction. The machine must not be lifted.

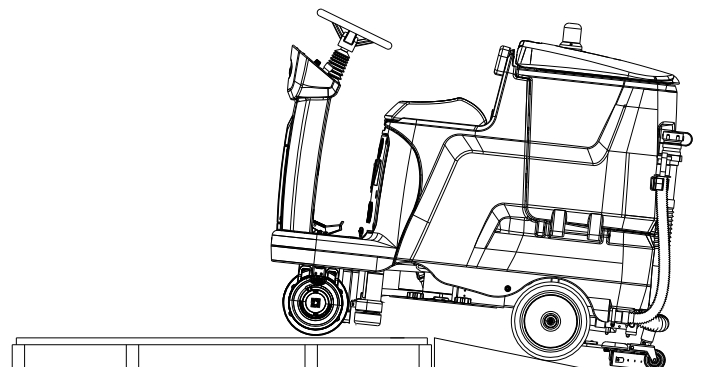

- Lock the motor wheel brake by turning the two screws anticlockwise.
- Refit the detergent solution filter cover and the side flaps.
- Remove the brushes from their packaging.
- Clean the outside of the machine, taking care to observe safety regulations.

Once the machine is clear of the packaging, proceed to install the batteries (refer to section “**Batteries: installation and connection**”).

The various items of packaging can be kept, if so desired, as these can be reused to protect the machine in the event of it being moved to a different site or sent to a repair workshop.

If not retained, the packaging must be disposed of in compliance with current regulations.

Batteries

! ATTENTION: do not use NON-rechargeable batteries

Two different types of battery may be installed on these machines:

Leak-proof tubular batteries (WET): the electrolyte level must be checked regularly.

GEL or AGM batteries: this type of battery requires no maintenance.

The technical specifications of the battery must correspond to those listed in the section on the “**Technical specifications**” of the machine. The use of heavier batteries could seriously jeopardize manoeuvrability and lead to the drive motor overheating. Lighter batteries of lower capacity, on the other hand, will need to be charged more frequently.

! NOTICE

Enter the type of battery installed in the machine software settings.

Follow the instructions below to adjust the machine logic settings for the type of battery installed.

- Press the emergency stop button to turn the machine off.

- Press the two “+” and “-” buttons simultaneously, then release the emergency stop button while continuing to hold the “+” and “-” buttons, until the battery identification “tipA”, “tipG” appears in the display.

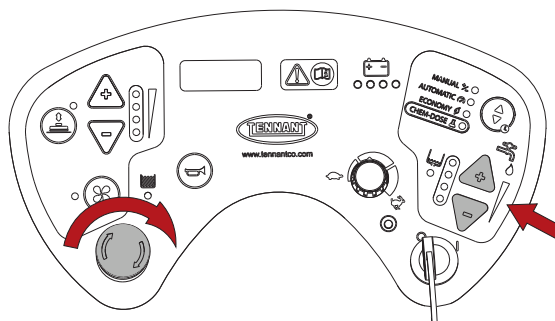

- Press the “solution flow selection” button to select the type of the batteries installed: “tipA” wet batteries, “tipG” gel batteries.

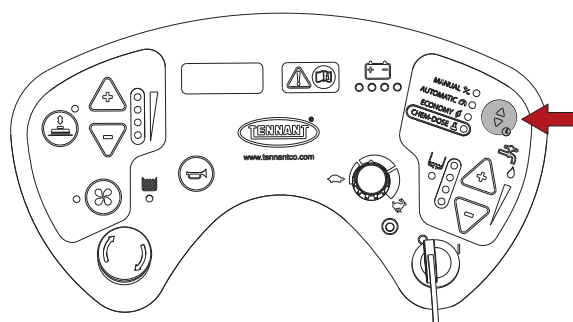

- Press the emergency stop button to store the parameter.

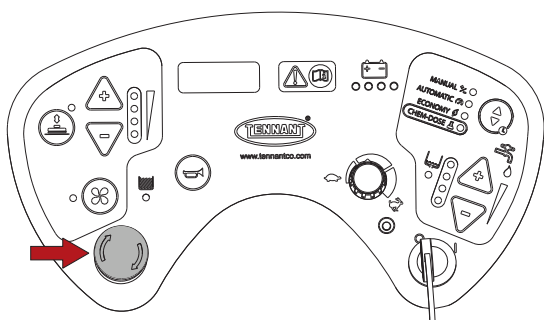
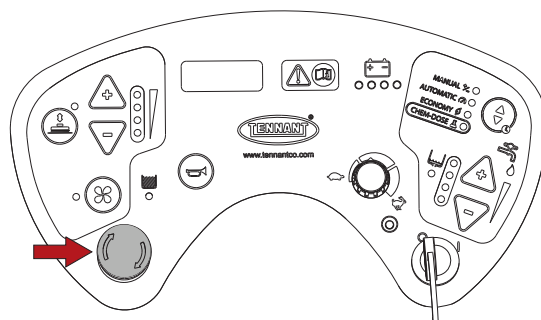

WET batteries, preparation:



! DANGER: The installation and connection/removal of the batteries must be entrusted to a TENNANT-approved service technician (referred to hereinafter as skilled technician).

! DANGER: during installation of the batteries or any type of battery maintenance, the skilled technician must wear the Personal Protective Equipment (gloves, eyewear, overalls, etc.) needed to limit the risk of accidents. Keep away from naked flames, do not short circuit the battery poles, do not generate sparks and do not smoke.

! DANGER: in the event of battery fluid leakage, do not touch the fluid and observe the following precautions:

Contact with the skin can cause irritation; wash with soap and water.

Inhalation of vapours can cause irritation to the airways; stay out in the open air and consult a doctor.

Contact with the eyes can cause irritation; wash the eyes immediately, flooding with water for at least 15 minutes, and consult a doctor.

(WET) Batteries are normally supplied filled with acid and ready for use.

If the batteries in use are dry charged, they must be activated before being installed in the machine. Proceed as follows:

Remove the caps and fill all elements with sulphuric acid solution specific for batteries until the plates are completely covered (this requires at least a couple of passes for each element). IF IN DOUBT, CONTACT YOUR LOCAL DEALER.

Leave the batteries to stand for 4-5 hours to allow air bubbles to come to the surface and the plates to absorb the electrolyte.

Make sure the level of electrolyte is still above the plates and if necessary top up with sulphuric acid solution;

Close the caps.

Install the batteries in the machine (following the procedure described below).

Charge the batteries before starting up the machine for the first time. Follow the instructions in the “Battery charging” section.

Batteries: installation and connection

! DANGER: during installation of the batteries or any type of battery maintenance, the skilled technician must be provided with the necessary personal protection devices (gloves, goggles, overalls, etc.) to limit the risk of accidents. Keep away from naked flames, do not short circuit the battery poles, do not generate sparks and do not smoke.

! DANGER: in the event of battery fluid leakage, do not touch the fluid and observe the following precautions:

Contact with the skin can cause irritation; wash with soap and water.

Inhalation of vapours can cause irritation to the airways; stay out in the open air and consult a doctor.

Contact with the eyes can cause irritation; wash the eyes immediately, flooding with water for at least 15 minutes, and consult a doctor.

! ATTENTION: the operation of installing and connecting the batteries must be carried out by qualified personnel.

! ATTENTION: when installing and connecting the batteries, ensure that the battery charger is unplugged from the power socket.

! ATTENTION: before carrying out the operations described below, stop on a flat and level surface, switch off the machine and remove the ignition key.

! DANGER: make certain the terminals marked with the “+” symbol are connected to the positive poles of the battery. Do not check the battery charge by sparking.

Tilt the tank backwards, then place the batteries in the compartment, positioning them as indicating by the drawing on the tank.

Connect the wiring terminals to the battery poles, tighten and cover with Vaseline.

Close the tank into the working position.

When using the machine, follow the instructions below.

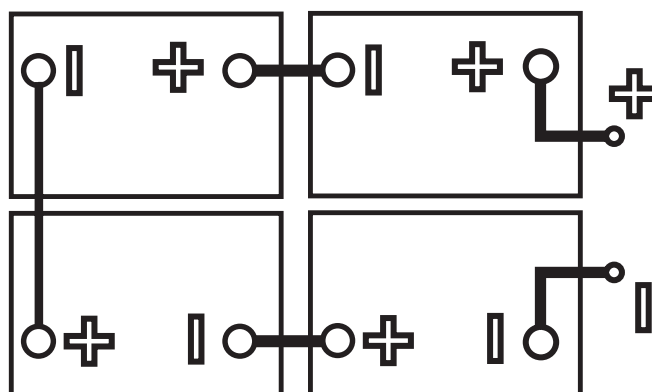

Selection of battery charger

! ATTENTION: where machines are shipped without batteries, the machine and the battery charger are factory set for GEL-AGM batteries as the default configuration. If the intention is to fit a different type of battery, the battery charger setting **MUST** be changed as described below. Failure to observe these instructions could result in damage to the battery. Depending on the type of battery selected (wet lead-acid or sealed gel / AGM), the battery parameters of the machine **MUST** be adjusted if different from the factory setting. For directions, see the section “Batteries”.

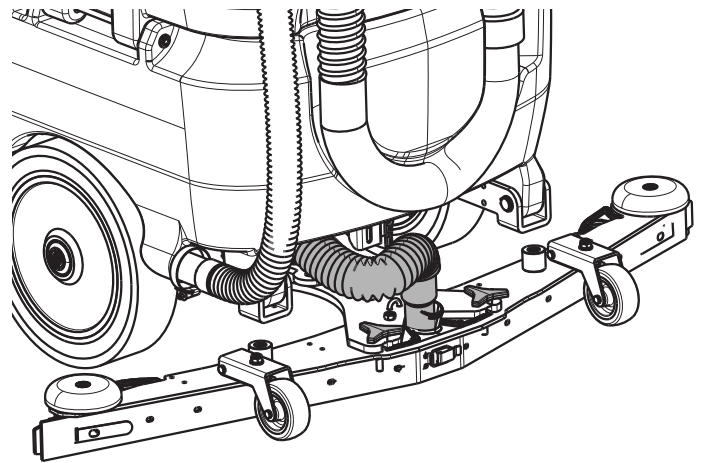

DIPSWITCHES: SW1		DIPSWITCHES: SW2			
DP1	DP2	DP1	DP2	CHARGING CURVE	
OFF	OFF	OFF	OFF	IUIa-ACD for Generic Wet batteries	
ON	OFF	OFF	OFF	IUIa-GEL for Exide-Sonnenschein Gel batteries	DEFAULT SETTING
OFF	ON	ON	ON	IUOU-GEL for Gel and AGM batteries	
ON	OFF	OFF	OFF	IUIa-AGM for Discover AGM batteries	
ON	ON	OFF	OFF	IUIa-GEL for Tojan	
ON	ON	ON	ON	IUIa (SO) GEL	

DIPSWITCHES: SW2		
DP2	TCL FUNCTION	
ON	TCL ENABLED	
OFF	TCL DISABLED	DEFAULT SETTING



Squeegee adjustment

! ATTENTION: before carrying out the operations described below, stop on a flat and level surface, switch off the machine and remove the ignition key.

The squeegee blades scrape the film of water and detergent from the floor and prepare the way for perfect drying. With time, and the constant wiping action, the edge of the blade in contact with the floor becomes rounded and cracked, diminishing its drying efficiency, so that ultimately a new blade is required. The state of wear should be checked frequently.

To ensure faultless drying, the squeegee must be adjusted as illustrated, in such a way that the edge of the rear blade deflects during operation by about 45° relative to the floor, at all points along its length. The angle of the blade during operation can be adjusted by regulating the height of the two wheels positioned in front of/behind the squeegee.

Fitting the squeegee

! ATTENTION: before carrying out the operations described below, stop on a flat and level surface, switch off the machine and remove the ignition key.

- Connect the suction hose to the squeegee, bending it to the position as illustrated.
- Loosen the two knobs.
- Locate the two threaded pins in the slots on the support.
- Tighten the two knobs.

The position of the squeegee is factory-set. Should the squeegee blade require adjustment, refer to the section “Squeegee adjustment”.

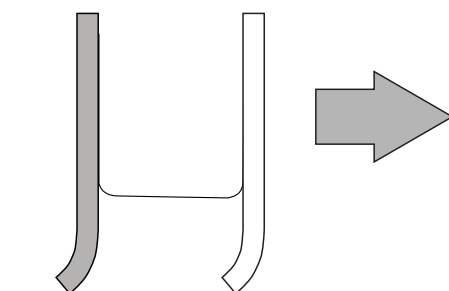

Fitting the brush/pad drivers

! ATTENTION: before carrying out the operations described below, stop on a flat and level surface, switch off the machine and remove the ignition key.

! NOTICE

Where the terms **RIGHT** and **LEFT** appear, this is always referred to the forward movement of the machine

Fitting the right brush (or abrasive disk):

- Remove the right hand side flap.
- Position the right hand brush, under the pad drive board.
- Lift the brush and turn it "clockwise" so that it locks to the drive.
- Reposition the right hand side flap.

Fitting the left brush (or abrasive disk):

- Follow the same procedure as indicated for fitting the right brush; in this instance the brush must be turned "counter-clockwise" to lock it to the pad drive board.

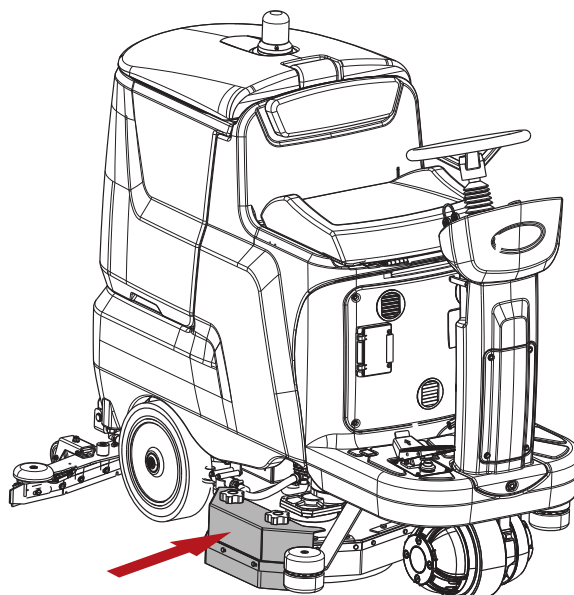
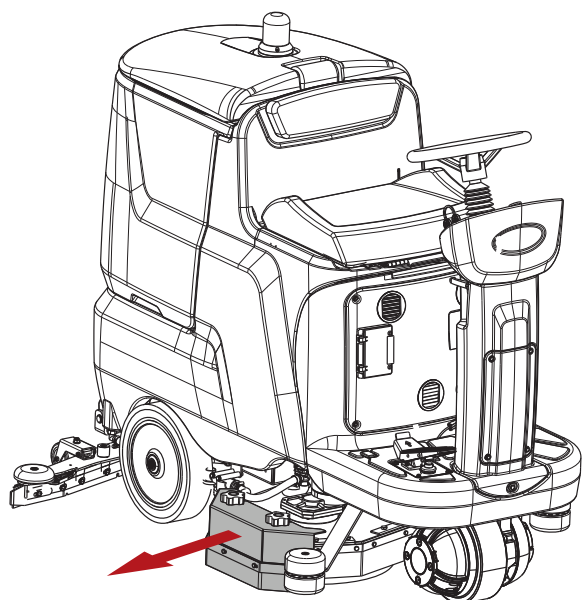
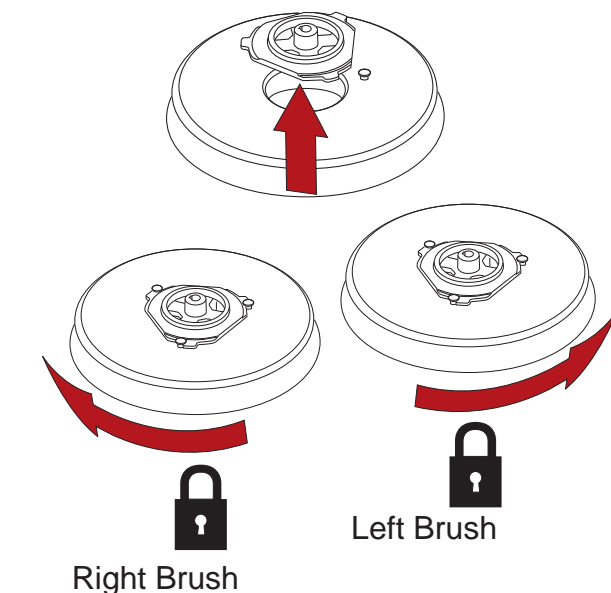
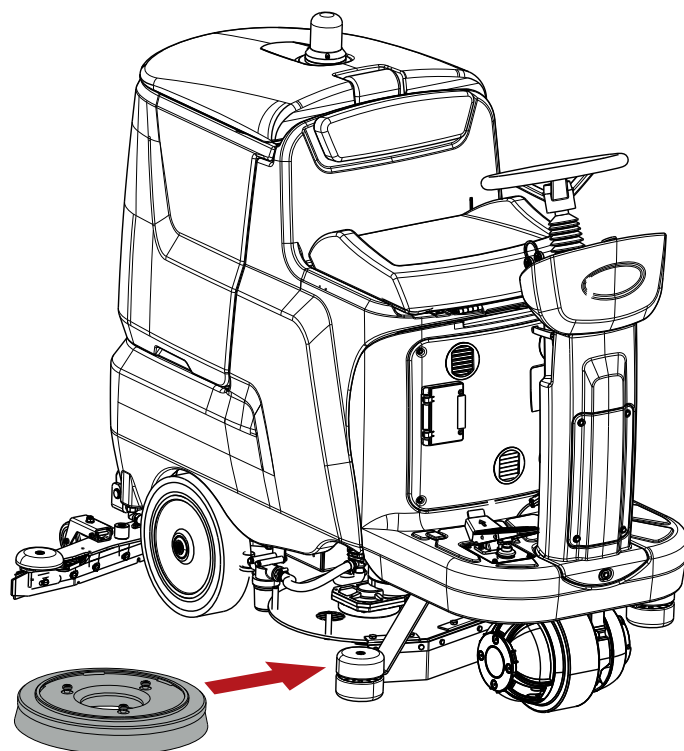

Fitting the brushes (Cylindrical Brush Model)

! ATTENTION: before carrying out the operations described below, stop on a flat and level surface, switch off the machine and remove the ignition key.

Assembly:

- Open the right and left hand side flaps, unscrewing the knobs.

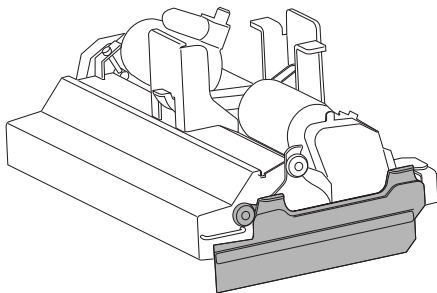

- Remove the covers of the brush compartment, unscrewing the knobs and pushing the covers downwards.

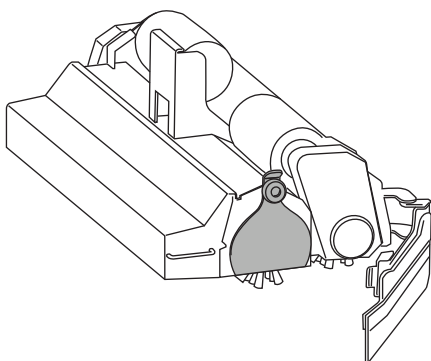

- Position the roller brushes in the two compartments, making certain that the guide pin on the opposite side is correctly located.

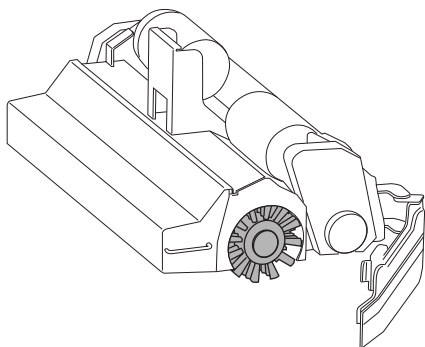

- Refit the two covers, then close the two flaps.

Disassembly:

- Repeat the steps described above in reverse order.

Filling the detergent tank

! ATTENTION: before carrying out the operations described below, stop on a flat and level surface, switch off the machine and remove the ignition key.



! DANGER: flammable liquids can be the cause of explosion or fire. Do not introduce flammable liquids into the tank.

! ATTENTION: fill the tank with detergent at a temperature of between 4 and 55 °C.

! ATTENTION: the machine has been designed for use with detergents supplied or recommended by the Manufacturer. The use of other detergents or chemicals can affect the safety of the machine.

! ATTENTION: the selected detergent should be utilized rationally, in accordance with the directions given on the packaging of the product.

! ATTENTION: select a detergent from the range of recommended products that is most suitable for the washing operation in hand, and dilute with water following the instructions on the pack or in the catalogue.

Fill the tank through the opening provided.

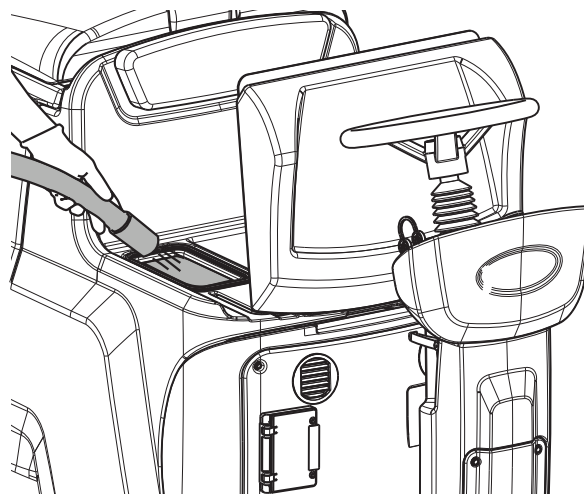

Chem Dose (accessory)

! ATTENTION: before carrying out the operations described below, stop on a flat and level surface, switch off the machine and remove the ignition key.

Position the detergent tank in the housing located under the driving seat.

Unscrew the cap of the detergent tank and insert the tapered plug and hose into the neck of the tank.

! DANGER: flammable liquids can be the cause of explosion or fire. Do not use flammable liquids.

! ATTENTION: the machine has been designed for use with detergents supplied or recommended by the Manufacturer. The use of other detergents or chemicals may jeopardise the safety of the appliance.

! ATTENTION: when using the Chem Dose accessory, the solution tank must be filled with **WATER ONLY**, at a temperature of between 4 and 55 °C. Do **NOT** put detergent solution into the tank.

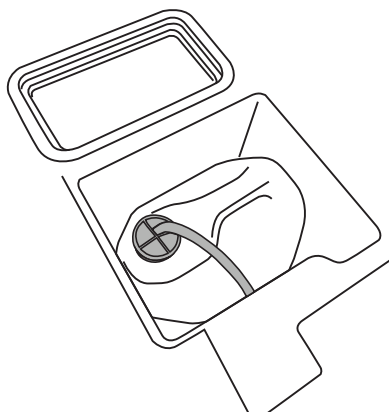
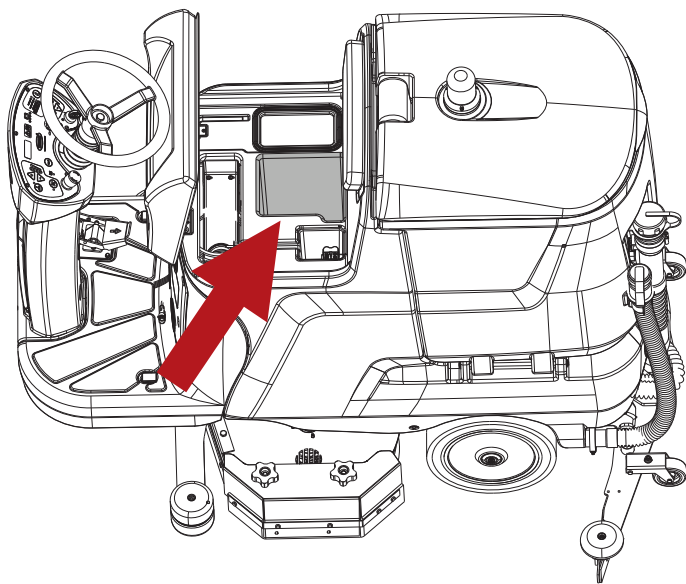

PRACTICAL GUIDE FOR THE OPERATOR

Clothing and equipment

Wear safety shoes with non-slip soles.
Wear protective goggles or visor and safety garments.
Depending on the surface being cleaned and on the environment, the protective measures necessary for atomized sprays include respiratory masks with class FFP2 or equivalent or higher protection.

Before starting the machine

Clear away larger items of refuse before washing. Pick up any pieces of wire, tape, string and similar items that could become entangled around the brushes.
Before washing is commenced, sweep the area so as to avoid the appearance of streaks on the floor.

Preparing the machine for work

- Proceed as follows before starting work.
- Check that the batteries are fully charged, and if not, carry out the recharging procedure: when undertaking this operation, refer to the section “**Charging the batteries**”.
 - Make certain that the dirty water tank is empty, and if not, empty it, referring to the section “**Emptying the dirty water tank**”.
 - Make certain that the solution tank is full, and if not, proceed to fill it, referring to the section “**Filling the water/detergent tank**”.
 - Make certain that the tank of the Chem Dose (accessory) is full, and if not, fill as required, referring to the section “**Chem Dose (accessory)**”.

! NOTICE
To make the machine more comfortable to use, the tilt angle of the steering wheel can be adjusted by means of the lever shown in the illustration below.

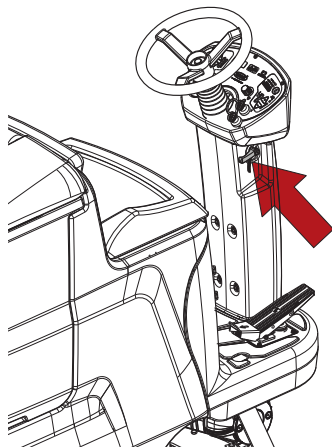

Working

! ATTENTION: do not use the machine without first reading the operating and maintenance manual.

! NOTICE
The machine is equipped with a safety system that prevents it from tipping over by noticeably reducing the speed when steering, independently of the pressure applied to the drive pedal. A loss of speed experienced when turning is therefore not a malfunction, but a feature that maximizes the stability of the machine in all conditions.

- Sit on the seat.
- Turn the ignition key to switch the machine on.

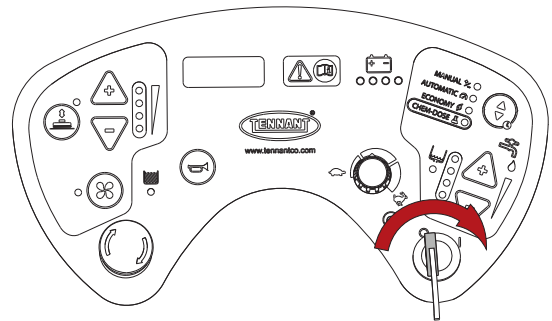

- Press the brush button: this enables the operation of the machine (brush motor, suction motor, brush head actuator and squeegee actuator)



- Using the “+” and “-” buttons, select the most suitable head/floor contact pressure, according to the type of washing operation in hand.

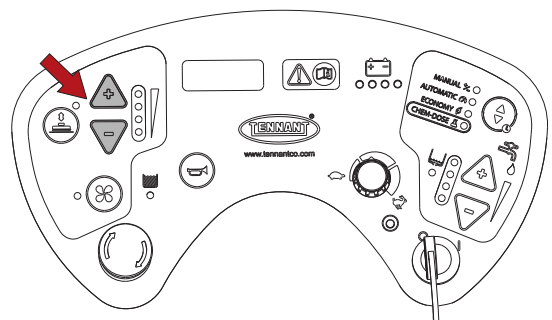

- Using the “SELECT” button, select the most suitable solution flow, according to the type of washing operation in hand. The following operating modes can be selected:

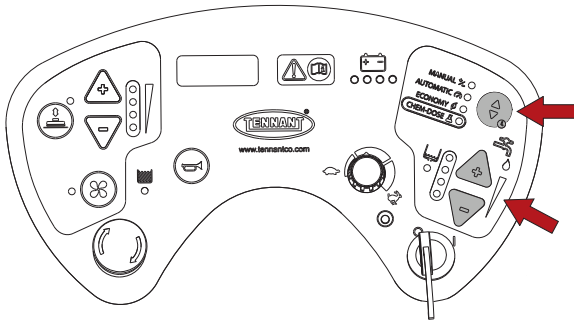

- STANDARD — the solution flow can be modified using the “+” and “-” buttons.
- AUTOMATIC — the solution flow is set by the machine according to the ground speed.
- ECONOMY — the solution flow rate is fixed at the lowest level.
- CHEM DOSE: this enables the CHEM DOSE function (optional). To activate CHEM DOSE mode, the “SELECT” button must be pressed and held until the red Led alongside the CHEM DOSE option lights up. To change the percentage of detergent in the solution, the flow options (STANDARD, AUTOMATIC, ECONOMY) must first be disabled by pressing the “SELECT” button repeatedly until only the CHEM DOSE Led remains alight; at this point the quantity of detergent can be varied by means of the “+” and “-” buttons; the value (%) set in this way appears in the display. Once the percentage of detergent has been set, the appropriate type of solution flow must be selected (STANDARD, AUTOMATIC, ECONOMY) using the “SELECT” button. To disable the CHEM DOSE function, press and hold the “SELECT” button for at least 5 seconds until the Led alongside the CHEM DOSE option extinguishes.

- Begin cleaning, manoeuvring the machine by turning the steering wheel and depressing the pedal to set the machine in motion: front part of the pedal for forward, rear part for reverse.

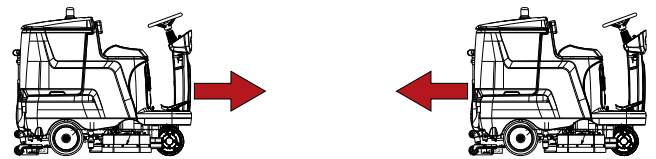
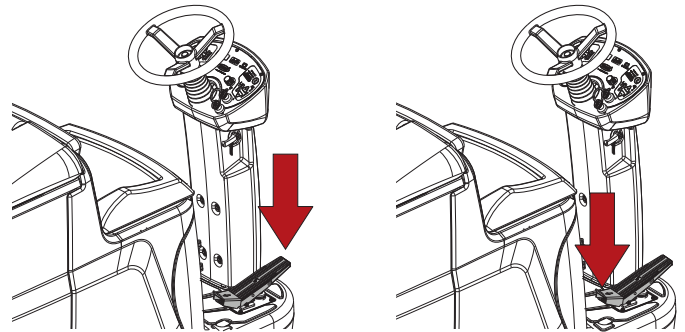

- The maximum operating speed can be set by turning the speed potentiometer.

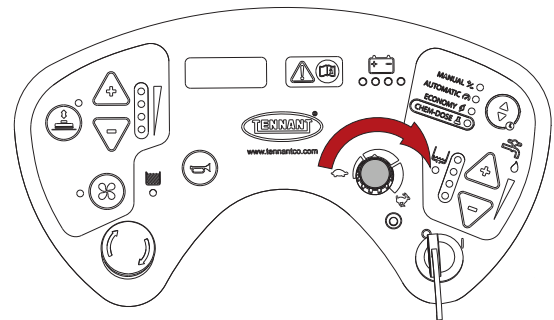

! NOTICE

Whenever the machine moves in reverse, the squeegee is raised automatically to prevent any possible damage.



! DANGER: Never use the machine to clean up flammable or explosive liquids (e.g. petrol, fuel oil, etc.), acids or solvents (e.g. paint thinners, acetone etc.) even if diluted.

To bring the machine to a halt, release the pedal. When the machine comes to a stop, the cleaning functions are deactivated and the parking brake is applied. Turn the ignition key to switch off the machine.

Dual wash

In cases where floors are soiled with particularly stubborn dirt, scrubbing and drying operations can be performed in two separate stages.

Prewash with brushes or pads:

- Turn the ignition key to switch the machine on.
- Press the brush button.



- Press the suction motor button: the suction fan switches off and the squeegee is raised.

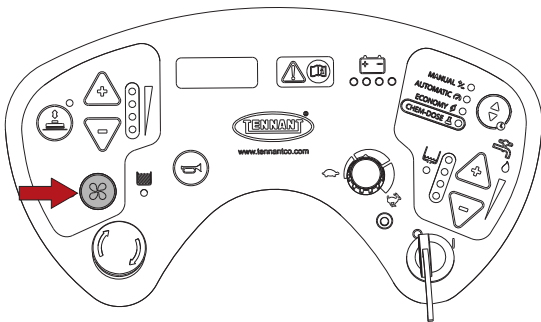

- Set the detergent solution flow.

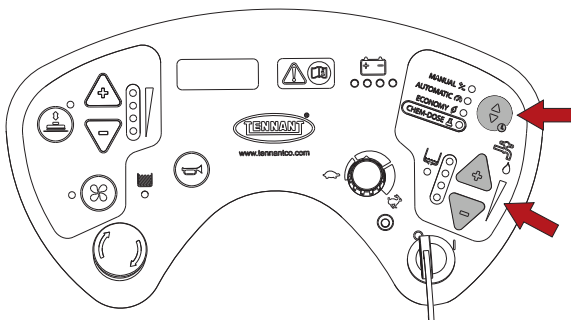

- When scrubbing particularly dirty areas, give the detergent sufficient time to perform its chemical action of detaching and suspending the dirt in the film of water, and allow the brushes time to exert an effective mechanical action.

Drying:

- Press the suction motor button: the suction fan switches on and the squeegee is lowered

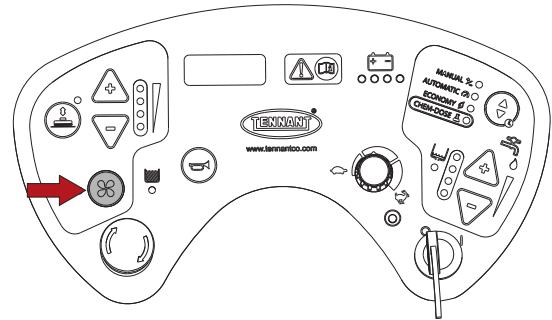

- Pass the machine over the area washed previously: the effect will be to produce a deep cleansing action, with the result that subsequent routine maintenance operations will take much less time.

Picking up water (without washing)

The machine can be used to mop up spills of water or NON-flammable liquids, without any cleaning action.

Press the suction motor button: the squeegee is lowered and the suction fan comes into operation.

Proceed to pick up the liquids.

During operation of the machine

- Keep the cleaning passes as straight as possible.
- Overlap successive cleaning passes by a few centimetres.
- Adjust the ground speed of the machine, the contact pressure of the brush and the flow of detergent to suit the type of cleaning. Use the minimum available settings, as far as practically possible, for the brush pressure and detergent solution flow.
- Check the battery charge indicator to ensure there will be sufficient power for completion of the cleaning operation.
- Check the detergent solution level indicator to ensure that the relative tank is not empty.
- Check the dirty water level indicator to ensure that the relative tank is not full.

! ATTENTION: do not attempt to clean surfaces on slopes or gradients steeper than indicated on the machine data plate.

! ATTENTION: Do not operate the machine on slopes or gradients steeper than indicated on the data plate.

! ATTENTION: When using the machine on gentle gradients, do not move transversely across the slope, but keep the machine on a line parallel to the direction of the incline, manoeuvring carefully and without making U-turns.

Emergency stop button

In the event of emergency, this button isolates the machine from its power source.

To cut off the power supply, press the button.

To restart the machine, rotate the button.

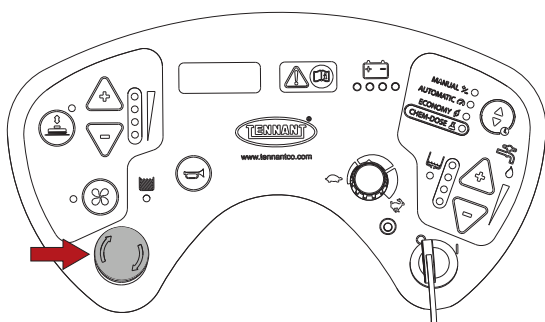

Battery charge indicator

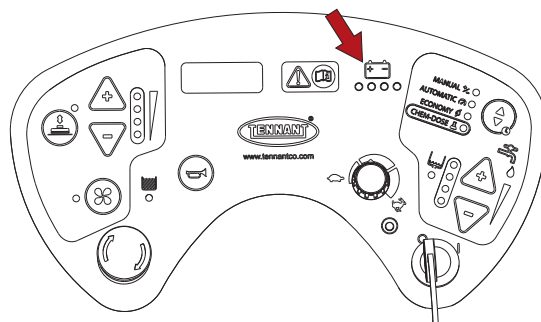

The indicator shows the level of charge remaining in the batteries, expressed in percentage terms.

When the batteries are completely discharged, all cleaning functions remain inhibited until recharging has taken place: when undertaking this operation, refer to the section **“Charging the batteries”**.

The battery charge status is indicated as follows:

- 1 red Led blinking: in this situation, the drive system is inhibited and the batteries must be recharged.
- 1 red Led permanently alight: battery charge level MINIMUM, cleaning functions inhibited.
- 1 red LED + 1 yellow Led permanently alight: battery charge level 20%.
- 1 red LED + 1 yellow Led + 1st green Led permanently alight: battery charge level MEDIUM.
- 1 red LED + 1 yellow Led + 1st green Led + 2nd green Led permanently alight: battery charge level MAXIMUM.

Detergent solution tank empty indicator

When the solution tank is empty, the indicator lights up and all cleaning functions are inhibited. The detergent solution tank must now be filled: when carrying out this operation, refer to the section **“Filling the detergent solution tank”**.

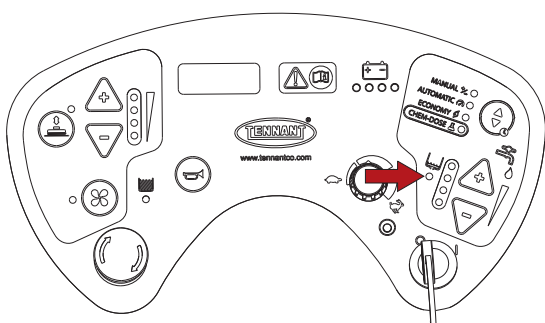

Dirty water tank full indicator

When the dirty water tank is full, the indicator lights up and all cleaning functions are inhibited. The dirty water tank must now be emptied: when carrying out this operation, refer to the section **“Emptying the dirty water tank”**.

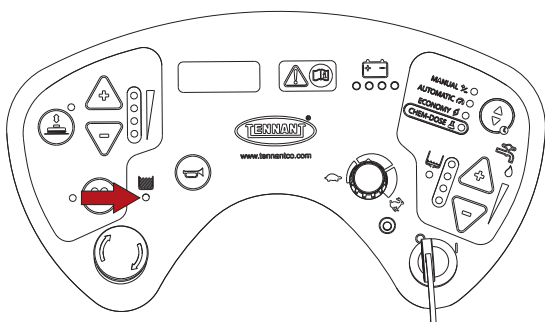

Emptying the dirty water tank

! ATTENTION: before carrying out the operations described below, stop on a flat and level surface, switch off the machine and remove the ignition key.

When cleaning operations have been completed, empty the dirty water tank.

If the tank is full, the indicator lights up and the cleaning functions of the machine will be inhibited; after a few seconds, the suction motor also shuts down. At this point the machine must be brought to a halt and the dirty water tank emptied, following the instructions indicated below:

- Switch off all functions of the machine.
- Take the machine to the designated service area.
- Unhook the hose from the clip.
- Empty the tank by way of the drain hose: keep the hose raised initially and remove the plug, then lower the hose gently and position it over the drain outlet.
- Rinse the tank with clean water.
- Rinse the float of the dirty water tank, referring to the directions given in the section “**Cleaning the dirty water tank sensor**”.
- Refit the plug to the drain hose and reattach the hose to the clip.

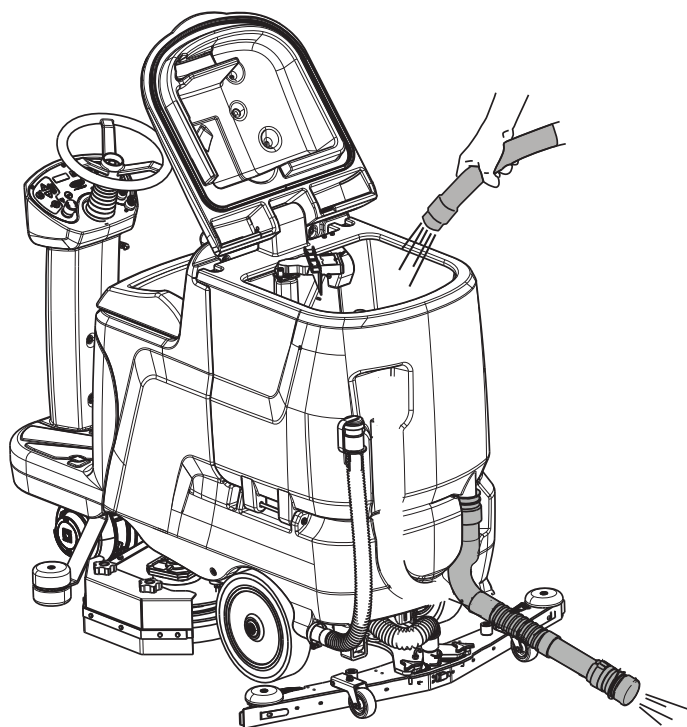

Emptying the solution tank

! ATTENTION: before carrying out the operations described below, stop on a flat and level surface, switch off the machine and remove the ignition key.

The detergent solution tank can be emptied by proceeding as follows:

- Switch off all functions of the machine.
- Take the machine to the designated service area.
- Unhook the hose from the clip.
- Empty the tank by way of the drain hose: keep the hose raised initially and remove the plug, then lower the hose gently and position it over the drain outlet.

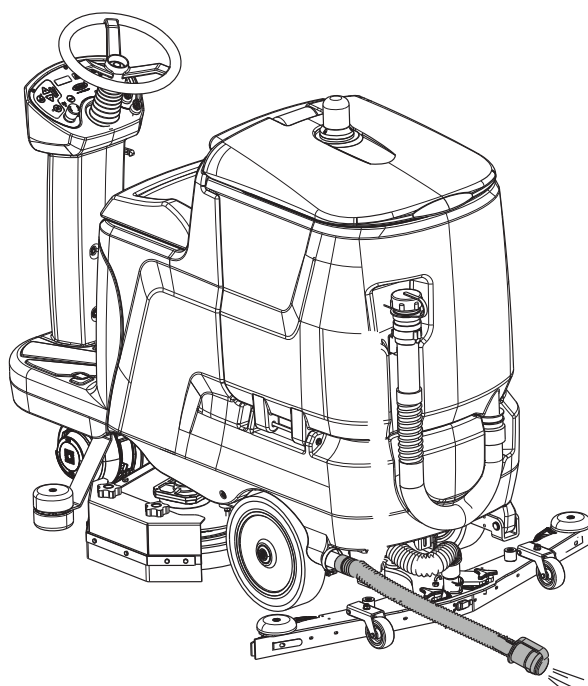

Emptying the Cylindrical Brush Model bin

! ATTENTION: before carrying out the operations described below, stop on a flat and level surface, switch off the machine and remove the ignition key.

Models with roller brushes: to empty the debris bin, remove by pulling out of the machine transversely. Empty the debris and wash the bin.

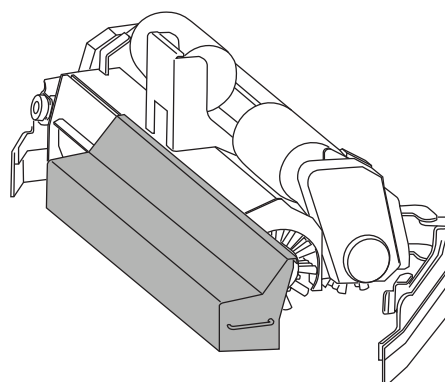

Removing the the brush/pad drivers

! ATTENTION: before carrying out the operations described below, stop on a flat and level surface, switch off the machine and remove the ignition key.

! NOTICE

Where the terms **RIGHT** and **LEFT** appear, this is always referred to the forward movement of the machine

Releasing the right hand brush (or abrasive disk):

- Remove the right hand side flap.
- Turn the brush "anticlockwise" to unlock it from the drive board.
- Reposition the right hand side flap;

Releasing the left hand brush (or abrasive disk):

- Follow the same procedure as used to remove the right brush, in this instance releasing it from the drive board by turning in the "clockwise" direction.

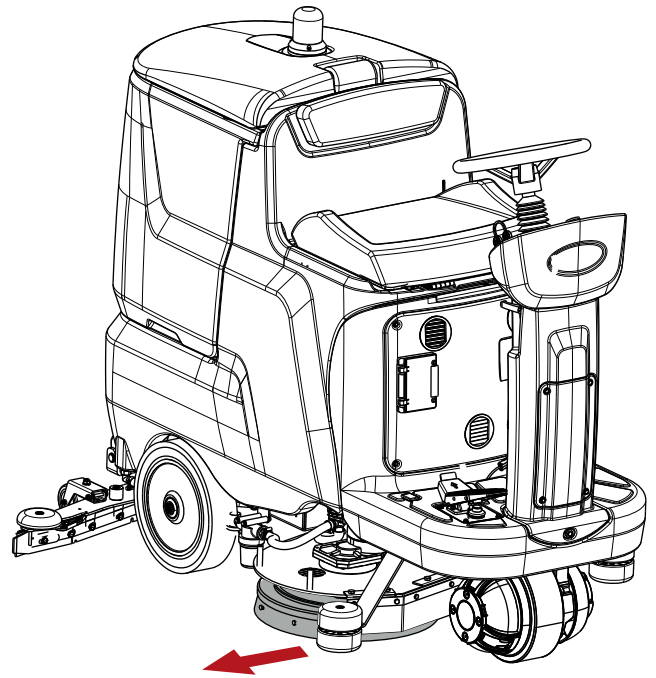

Moving the machine when not in operation

To move the machine, proceed as follows:

- Turn the ignition key to switch the machine on.
- Depress the drive pedal: for forward motion, press down on the front half of the pedal; for reverse motion, on the rear half.
- The top speed of the machine is adjusted by turning the potentiometer.

To bring the machine to a halt, release the pedal.

When the machine comes to a stop, the parking brake is applied.

Turn the ignition key to switch off the machine.

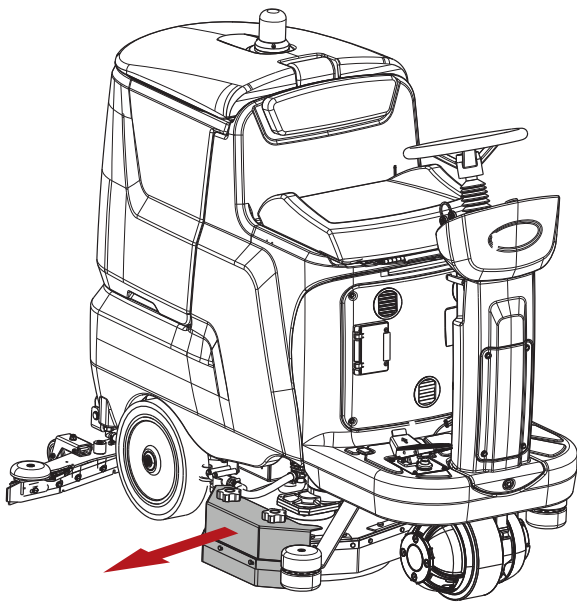

MAINTENANCE INSTRUCTIONS

! DANGER: no maintenance work of any description must be carried out without first having isolated the machine from its power source. Maintenance operations on the electrical circuit — and in any event, all other operations not explicitly described in this operating manual — must be performed by a TENNANT approved service technician, in compliance with current safety regulations and as indicated in the maintenance manual.

! DANGER: before lifting/turning the tank to access the housing, it must be emptied of its contents.

Maintenance - General rules

Performing regular maintenance according to the Manufacturer's instructions will improve performance and extend the working life of the machine.

When cleaning the machine, always observe the following precautions:

Avoid using pressure washers. Water could penetrate the electrical compartment or motors leading to damage or short circuits;

Avoid using steam, as the heat could cause the deformation of plastic parts;

Do not use solvents or hydrocarbon based products. These can damage the cowling and rubber components.

Cleaning the suction motor air filter

Raise the lid of the dirty water tank, then remove the filter from its housing and wash it under running water or using the detergent dispensed by the machine; dry the filter thoroughly before repositioning it in the housing.

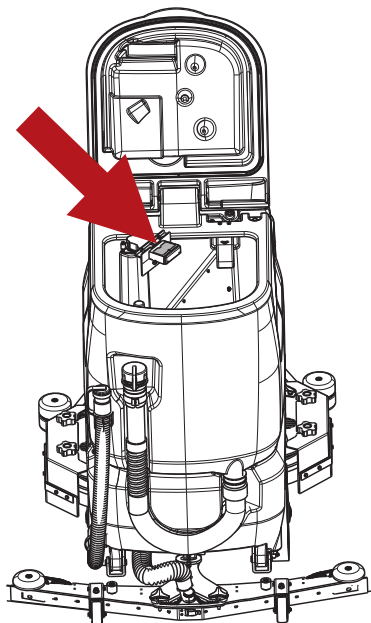

Cleaning the dirty water tank sensor

Raise the lid of the dirty water tank, remove the protection, and clean the sensor as appropriate.

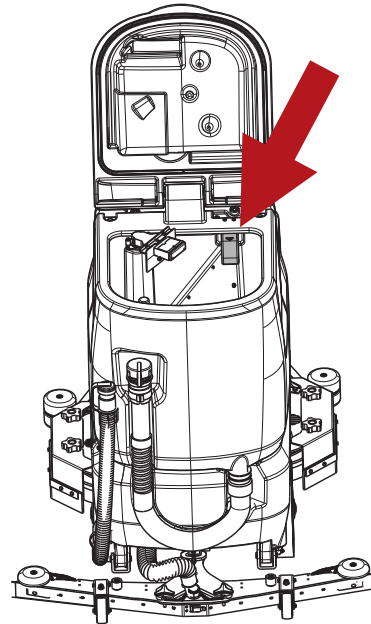

Cleaning the solution tank filter

To clean the filter, proceed as follows:

- Shut off the tap upstream of the filter.
- Unscrew the filter cap, remove the filter, then wash under running water or using the same detergent dispensed by the machine.
- Replace the filter in its housing, making sure it is correctly positioned and screw the lid back on.

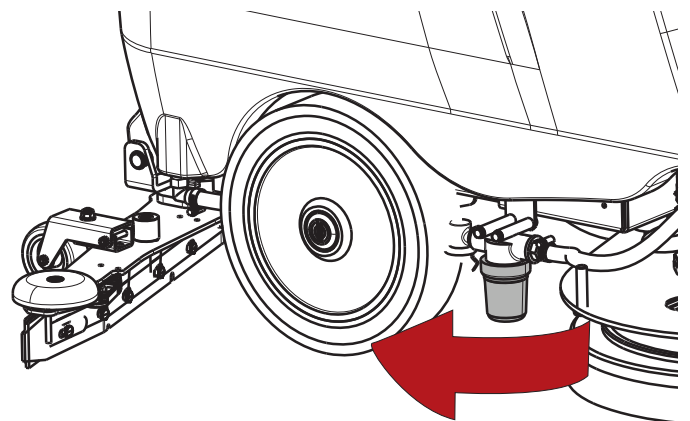

Fuses: replacing

! ATTENTION: never install a fuse with a current rating higher than that specified.

The replacement of fuses must be entrusted only to a TENNANT service centre or to a TENNANT-approved service technician.

Elevate the tank, disconnect the battery wiring connector from the electrical system or unplug the mains power cable, and remove the cover to access the fuses.

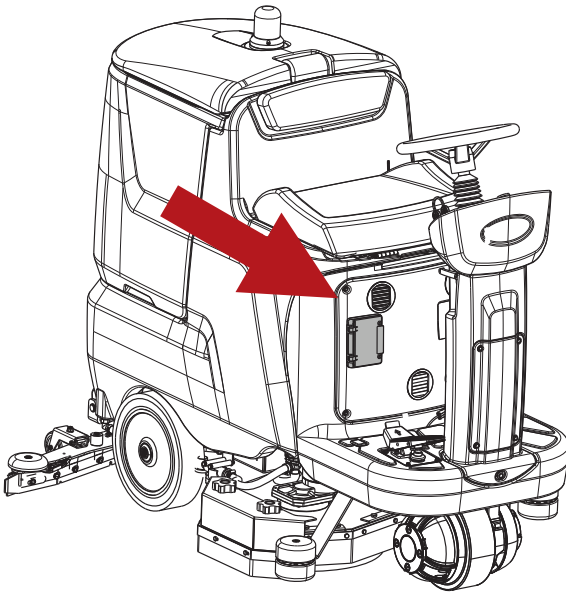

Battery maintenance

! DANGER: do not check the batteries by sparking. Lead-acid (WET) batteries give off flammable vapours: extinguish any naked flames or embers before checking or topping up the batteries.

! DANGER: during any type of maintenance on the batteries, the skilled technician must wear the Personal Protective Equipment (gloves, eyewear, overalls, etc.) needed to limit the risk of accidents. Keep away from naked flames, do not short circuit the battery poles, do not generate sparks and do not smoke.

! DANGER: in the event of battery fluid leakage, do not touch the fluid and observe the following precautions:
Contact with the skin can cause irritation; wash with soap and water.
Inhalation of vapours can cause irritation to the airways; stay out in the open air and consult a doctor.
Contact with the eyes can cause irritation; wash the eyes immediately, flooding with water for at least 15 minutes, and consult a doctor.

! ATTENTION: before carrying out the operations described below, stop on a flat and level surface, switch off the machine and remove the ignition key.

Useful battery life is dependent on proper maintenance. To obtain best possible efficiency from batteries, observe the following rules:

- Do not leave batteries partially discharged for long periods of time.
- Allow batteries to charge completely before resuming use of the machine.
- Keep batteries clean, with the connections always well tightened.
- Check the level of the electrolyte every week (WET batteries).

Checking the electrolyte level of WET batteries

WET batteries must be inspected periodically to check the level of the electrolyte. Use only distilled water to top up the level so that the plates are covered. Do not overfill (maximum 5 mm above the plates), as the electrolyte could expand and overflow when the battery is charged.

Recharging the batteries

! ATTENTION: before carrying out the operations described below, stop on a flat and level surface, switch off the machine and remove the ignition key.

! DANGER: do not check the batteries by sparking. Lead-acid (WET) batteries give off flammable vapours: extinguish any naked flames or embers before checking or topping up the batteries.

! DANGER: carry out the operations described below in a ventilated area.

! DANGER: when charging the batteries, highly explosive hydrogen gas is produced. Elevate the tank for the entire duration of the battery charging cycle and carry out the procedure only in well ventilated areas away from naked flames.

! ATTENTION: before recharging, make certain that the battery charger is set up correctly for the type of battery installed.

! ATTENTION: run the recharge cycle exactly as specified in the battery charger manual, and at the end of the cycle, detach the connectors.

- Take the battery charger plug from its housing.
- Plug into the mains power socket.
- Start the recharge cycle.

Battery: removal



! DANGER: in the event of battery fluid leakage, do not touch the fluid and observe the following precautions:

Contact with the skin can cause irritation; wash with soap and water.

Inhalation of vapours can cause irritation to the airways; stay out in the open air and consult a doctor.

Contact with the eyes can cause irritation; wash the eyes immediately, flooding with water for at least 15 minutes, and consult a doctor.



! DANGER: When removing the batteries, the skilled technician must wear the Personal Protective Equipment (gloves, eyewear, overalls, etc.) needed to limit the risk of accidents; remove the ignition key from the control panel before proceeding with the removal operation, keep away from naked flames, do not short circuit the battery poles, do not cause sparks and do not smoke.

! ATTENTION: the operation of removing the batteries must be carried out by a skilled technician.

! ATTENTION: when removing the batteries, ensure that the battery charger is unplugged from the power socket.

! ATTENTION: before carrying out the operations described below, stop on a flat and level surface, switch off the machine and remove the ignition key.

- Disconnect the battery cables and bridge terminals from the battery poles.
- If necessary, remove the devices fixing the battery to the base of the machine.
- Lift the batteries from the compartment using suitable handling equipment.

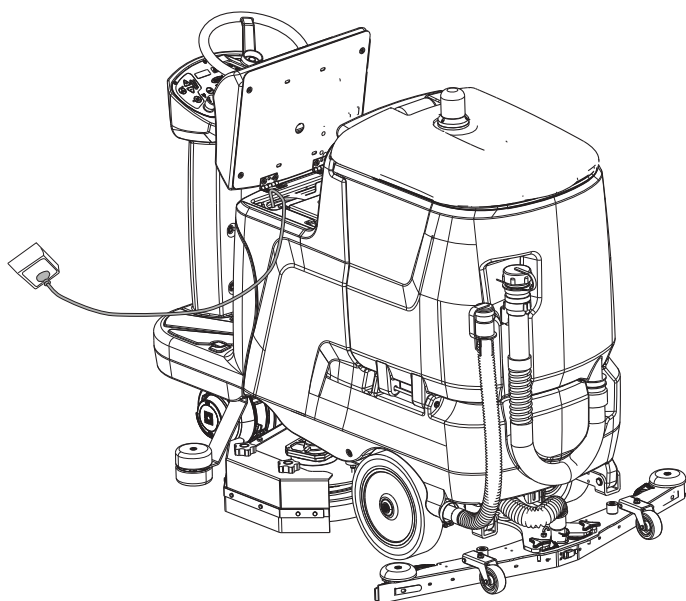

Battery charger error codes

Warning	Meaning
Red Led blinking (twice)	Battery charger configured for recharging lead-acid batteries
Green Led blinking (twice)	Battery charger configured for recharging GEL and/or AGM batteries
Red Led permanently alight	First stage of normal charging
Yellow Led permanently alight	Second stage of normal charging
Green Led permanently alight	Charging complete or maintenance in progress
Abnormalities	
Yellow Led blinking	Wrong battery, battery not connected, output short-circuit
Red LED blinking	Safety timeout exceeded, internal short-circuit

RED LED YELLOW LED GREEN LED

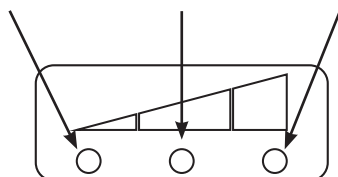

Replacement of Brushes and Pads

! ATTENTION: before carrying out the operations described below, stop on a flat and level surface, switch off the machine and remove the ignition key.

The machine can be equipped with disc brushes, roller brushes and pads. Check the brushes and the pads every day to make certain there are no wires, threads or strings entangled around the brush or the drive board. Check for wear on the brushes and the pads.

Replaces the brushes when the bristles are worn down to the point of exposing the red or black indicator.

Replace the pads when they no longer clean efficiently.

Wash the brushes and pads with soap and water following use, and hang them up to dry.

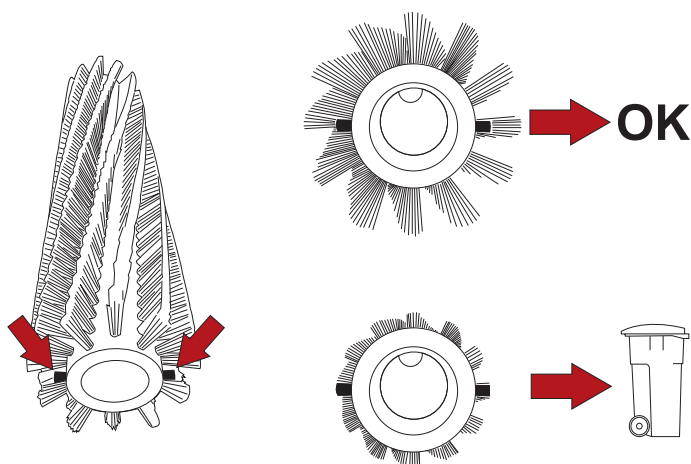
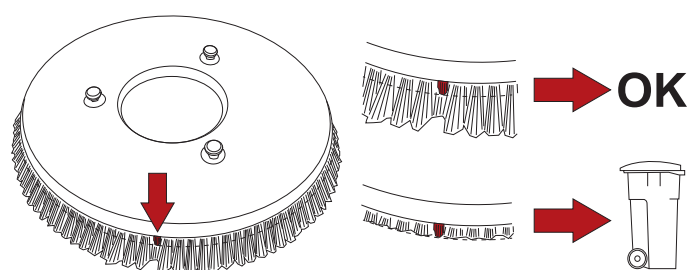

Replacing the squeegee blades

! ATTENTION: before carrying out the operations described below, stop on a flat and level surface, switch off the machine and remove the ignition key.

The squeegee blades collect the film of water and detergent from the floor and prepare the way for perfect drying. With time, and the constant wiping action, the edge of the blade in contact with the floor becomes rounded and cracked, diminishing its drying efficiency, so that ultimately a new blade is required.

- Remove the suction hose from the squeegee.
- Remove the squeegee from its mount by unscrewing the two knobs completely.
- Release the locking catch / or unscrew the bolt.
- Remove the two blade retainers by pushing them toward the outside of the squeegee then pulling them out.

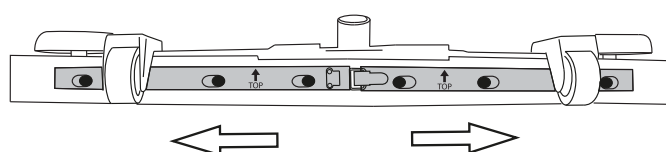
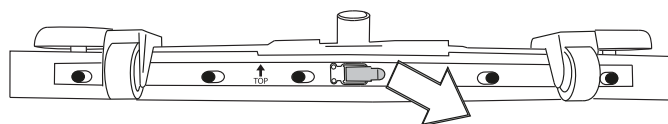

- Remove the blade.
- Refit the same blade, switching it around so that all four edges in turn are placed in contact with the floor, until all are worn out, or replace with a new blade, fitting it to the screws on the body of the squeegee.
- Reposition the two blade retainers by aligning the widest part of the slots with the fixing screws on the squeegee body, then pushing the blade retainers inwards.

! NOTICE

Position the two blade retainers, ensuring that the arrows printed on the blade retainers are facing upwards.

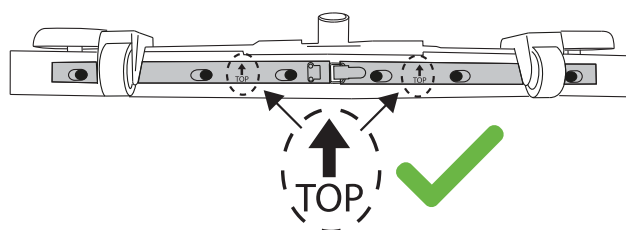

- Re-engage the locking catch / or tighten the bolt.
- Replace the squeegee on its mount.

Periodic checks

CHECK	DAILY OPERATIONS	WEEKLY OPERATIONS	SIX MONTHLY OPERATIONS
EMPTY AND WASH THE DIRTY WATER TANK	X		
CLEAN THE SQUEEGEE BLADES AND CHECK THEM FOR WEAR	X		
CHECK THAT THE SUCTION HOLE IN THE SQUEEGEE IS NOT BLOCKED	X		
RECHARGE THE BATTERIES	X		
CLEAN THE DIRTY WATER TANK FLOAT		X	
CLEAN THE SUCTION MOTOR AIR FILTER		X	
CLEAN THE WATER/DETERGENT TANK FILTER		X	
CLEAN THE SUCTION MOTOR HOSE		X	
CLEAN THE DIRTY WATER TANK AND THE SOLUTION TANK		X	
CHECK THE BATTERY ELECTROLYTE LEVEL		X	
HAVE THE ELECTRICAL SYSTEM CHECKED BY A TENNANT-APPROVED SERVICE TECHNICIAN			X

PERIODS OF INACTIVITY

If the machine is not used for some time, for example, on display in a showroom or stored in the warehouse for a period of more than one month, the following operations are required:

- Recharge the batteries completely. During long periods of inactivity, remember to recharge the batteries periodically (at least once every two months) so that they are kept at the maximum charge level.
- Disconnect the batteries from the machine.
- Unplug the battery charger (if present) from the mains power supply.
- The squeegee and brushes (or abrasive disks) must be removed from the machine, washed and stored in a dry place (preferably in a bag or wrapped in plastic sheet) away from dust.
- Make certain that the tanks are completely empty and perfectly clean.

! ATTENTION: remember to check the batteries — if they are not recharged periodically as described above, they could become damaged beyond repair. The manufacturer is not liable for any malfunctions resulting from neglect, improper and/or incorrect use.

! ATTENTION: when the batteries discharge to the minimum level, make certain they are not left in this condition for any length of time, as this can reduce their working life. Check the battery charge level at least once a week

TROUBLESHOOTING

PROBLEMS	CAUSES	SOLUTIONS
The machine does not work	The batteries are disconnected	Connect the batteries to the machine
	The batteries are flat	Recharge the batteries
	Blown fuse	Replace
	Ignition key not engaged	Turn the key
	Emergency button pressed	Release the emergency button
The brushes do not turn	The dirty water tank is full	Empty the dirty water tank
	Blown fuse	Replace
	The batteries are flat	Recharge the batteries
	Damaged motor	Replace
The machine does not clean uniformly	The brush or disks are worn	Replace
No solution comes out of the detergent tank	Damaged solenoid valve	Replace
	Dirty solenoid valve	Check
	Detergent solution tank empty	Top up
	The hose delivering detergent to the brush is blocked	Unblock
	The tap upstream of the filter is closed	Open the tap
	Blown fuse	Replace
Detergent flow does not stop	Damaged solenoid valve	Replace
	Dirty solenoid valve	Clean
The suction motor does not start	The dirty water tank is full	Empty the dirty water tank
	Blown fuse	Replace
	The batteries are flat	Recharge the batteries
	Damaged motor	Replace
The squeegee does not clean or has poor suction	The edge of the rubber blades in contact with the floor is worn	Replace the blades
	Squeegee blocked or damaged	Check
	The dirty water tank float is activated or is blocked by dirt, or is faulty	Empty the dirty water tank, check the float.
	Blockage in the suction hose	Check
	The suction hose is not connected to the squeegee or is damaged	Check
	The blade retainers may be fastened upside down	Check for proper orientation
The machine does not move	The batteries are flat	Recharge the batteries
	Damaged motor	Replace
The machine does not brake	Electromagnetic brake clamp screws loose	Tighten the screws
	Electromagnetic brake faulty	Replace
The batteries do not provide the normal working time	The battery poles and charging terminals are dirty and oxidised	Clean and grease the poles and terminals, charge the batteries
	The electrolyte has evaporated and is not covering the plates completely	Top up all elements with distilled water so that all plates are covered, then recharge the battery.
	The battery charger does not work or is not suitable	Check

RECOMMENDED SPARE PARTS

T681 70cm Disk Wear Parts	
9017801	BLADE, SQGE, FRONT, 1020L, LATEX
9017804	BLADE, SQGE, REAR, 1020L, LATEX
9017806	BLADE, SQGE, FRONT, 1020L, PYU
9017811	BLADE, SQGE, REAR, 1020L, PYU
9017813	BLADE, SQGE, FRONT, 1020L, LINATEX [STANDARD]
9017814	BLADE, SQGE, REAR, 1020L, LINATEX [STANDARD]
9017816	BRUSH ASSY, DISK, SCB, 35CM, 3-LUG, PYP [STANDARD]
9017730	BRUSH ASSY, DISK, SCB, 35CM, 3-LUG, PYP, SOFT
9017818	BRUSH ASSY, DISK, ABR, 35CM, 3-LUG, 120 GRIT
9017820	DRIVER ASSY, PAD, 35CM, 3-LUG
MPVR05223	FLAP, LH SIDE, SKIRT
MPVR05222	FLAP, RH SIDE, SKIRT
T681 70cm Disk Service Parts	
9017687	CARBON, BRUSH, MOTOR, VAC FAN
9017792	MOTOR, BRUSH
9017686	CARBON, BRUSH KIT, MOTOR, BRUSH [4 PC]
MEVR00985	CARBON, BRUSH KIT, MOTOR, TRACTION
MOCC00273	MOTOR, VACUUM, 24V
9017714	GASKET, MOTOR, VACUUM
9017713	FILTER, VACUUM
KTRI04699	HOSE ASSY, RECY
GUVR00311	GASKET, FILTER, SOLUTION
9017790	SENSOR, LEVEL, LIQ
9017737	FLOAT, SHUTOFF
9017793	HOSE, DRAIN, RECY
MEVR02667	POTENTIOMETER, 5K
KTRI05576	POTENTIOMETER, SPEED 100K
MEEV00044	SOLENOID VALVE
897143	INSULATION, ACSTC
FTAC00038	FILTER, SOLUTION, ASSEMBLY
FTAC00047	FILTER, SOLUTION
MOCC00322	ACTUATOR, SQGE
MOCC00323	ACTUATOR, SCRUB HEAD
KTRI02209	DRIVE ASSY, WHEEL [T681]
RTRT00533	MOTORWHEEL, RING REPLMT
MOCC00399	MOTOR, TRACTION
RDGR00040	GEAR BOX, TRACTION
MEVR02030	BRAKE, MOTOR WHEEL
MECI00532	CONTACTOR, 24V-100A
METT45116	CONTACTOR, T106P, 24V
RTRT00539	WHEEL, REAR, PYU [T681]
MLML00327	POTENTIOMETER, SPRING
MECE00575	CIRCUITBOARD ASSY, ACTUATOR [T681]
MEVR00145	FUSE 100A
METT00132	FUSE 30A
METT00133	FUSE 25A
METT00134	FUSE 1A
METT00135	FUSE 2A

METT00136	FUSE 3A
METT00137	FUSE 4A
MECE00916	CIRCUITBOARD ASSY, TRACTION [T681]
MECE00451	CIRCUITBOARD ASSY, CONTROL [T681]
PMVR06665	SQUEEGEE ASSY, LINATEX BLADES, 70CM DISK
BACA00285	CHARGER, 24VDC/25A, 100-240VAC
MECB02065	CORD, POWER, CHRGR [ANZ]

Tennant Company

PO. Box

10400 Clean Street

Eden Prairie, MN 55344-2650

Phone: (800) 553- 8033

www.tennantco.com

Copyright © 2021 Tennant Company. All rights reserved.